

## RECT TUBE

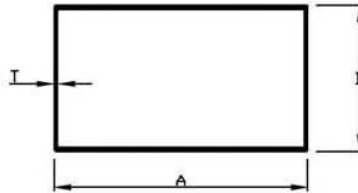

SEC.No.	C/L	A	B	T	WEIGHT
1000	12	36.00	24.00	0.54	0.600-0.720
1001	12	36.00	24.00	0.69	0.750-0.850
1002	12	36.00	24.00	0.75	0.850-1.000
1003	12	36.00	24.00	0.86	1.000-1.300
1004	12	36.00	24.00	1.12	1.300-1.500
1025	12	36.00	24.00	1.55	1.700-2.000
1029	12	48.00	24.00	0.55	0.750-0.850
1005	12	48.00	24.00	0.67	0.900-1.200
1006	12	48.00	24.00	0.86	1.200-1.400
1007	12	48.00	24.00	1.05	1.450-1.700
1009	12	48.00	24.00	1.25	1.700-1.900
1010	12	48.00	24.00	1.42	1.900-2.100
1011	12	48.00	24.00	1.60	2.200-2.400
1012	12	48.00	24.00	2.00	2.750-3.000
1013	12	63.00	38.00	0.78	1.500-1.800
1014	12	63.00	38.00	0.93	1.800-2.000
1015	12	63.00	38.00	1.46	2.800-3.000
1016	12	75.00	25.00	0.65	1.500-1.700
1017	12	100.0	25.00	1.00	2.400-2.600
1018	12	100.0	38.00	2.00	5.200-5.600
1019	12	101.6	44.45	1.15	3.200-3.500
1020	12	101.6	44.45	1.40	3.800-4.100
1021	12	100.0	38.00	1.05	2.700-3.000
1022	12	50.00	25.00	1.10	1.700-1.900
1023	12	63.00	38.00	1.10	2.500-2.800
1024	12	63.00	25.00	0.75	1.200-1.500
1028	12	75.00	25.00	1.50	2.850-3.200
1026	12	100.0	25.00	1.50	3.600-3.800
1027	12	100.0	19.00	1.70	3.800-4.100
1030	12	50.00	25.00	1.50	2.100-2.300
1031	12	100.0	50.00	2.00	5.750-6.000
1032	12	75.00	50.00	1.86	4.500-4.800
1033	12	100.0	50.00	1.70	4.900-5.200
1034	12	75.00	38.00	2.00	4.300-4.600
1035	12	81.00	38.50	1.85	4.000-4.300
1036	12	50.00	38.00	1.30	2.150-2.400
1037	12	63.00	38.00	1.10	2.100-2.400
1038	12	50.00	38.00	1.90	3.200-3.500

# RECT TUBE

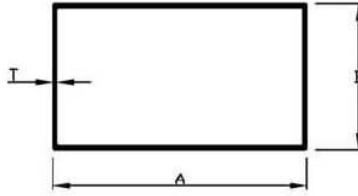

SEC.No.	C/L	A	B	T	WEIGHT
1039	12	52.00	38.00		4.900-5.300
1040	12	100.00	50.00	3.00	9.100-9.500
1041	12	63.00	38.00	2.00	4.000-4.500
1042	12	36.00	24.00		2.300-2.500
1043	12	75.00	19.00		3.300-3.600

## SQ. TUBE

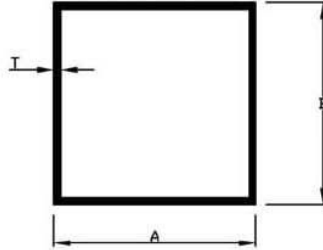

SEC.No.	C/L	A	B	T	WEIGHT
1050	12	19.00	19.00	1.20	0.800-1.100
1051	12	19.00	19.00	2.00	1.300-1.450
1055	12	25.00	25.00	0.78	0.750-0.850
1052	12	25.00	25.00	0.95	0.900-1.000
1056	12	25.00	25.00	1.65	1.500-1.700
1053	12	38.00	38.00	1.09	1.600-1.800
1057	12	38.00	38.00	1.50	2.100-2.400
1058	12	38.00	38.00	2.00	2.800-3.100
1054	12	50.00	50.00	1.06	2.000-2.200
1059	12	50.00	50.00	1.40	2.600-2.800
1060	12	50.00	50.00	2.00	3.800-4.100

## SINGLE PARTITION

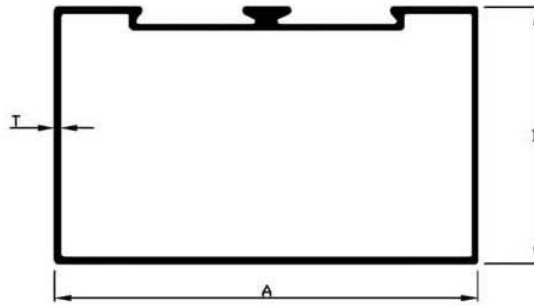

SEC.No.	C/L	A	B	T	WEIGHT
1081	16	50.00	25.00	0.87	1.900-2.100
1090	16	50.00	25.00	1.40	2.200-2.500
1082	12	50.00	25.00	1.50	2.500-2.700
1083	15	63.00	38.00	0.94	2.500-2.700
1095	16	63.00	38.00	1.00	2.800-3.000
1091	16	63.00	38.00	1.10	3.000-3.300
1084	16	63.00	38.00	1.25	3.400-3.600
1096	16	63.00	38.00	1.50	4.100-4.400
1085	16	63.00	38.00	1.69	4.700-5.000
1086	16	63.00	38.00	1.97	5.300-5.500
1093	16	63.00	38.00	2.50	6.500-6.800
1092	16	63.00	38.00	3.00	7.600-8.100
1087	15	101.0	44.45	1.25	4.650-4.800
1094	16	101.0	44.45	1.60	6.400-6.800
1088	16	101.0	44.45	2.00	7.700-7.900
1089	16	101.0	44.45	3.00	11.40-11.60

## DOUBLE PARTITION

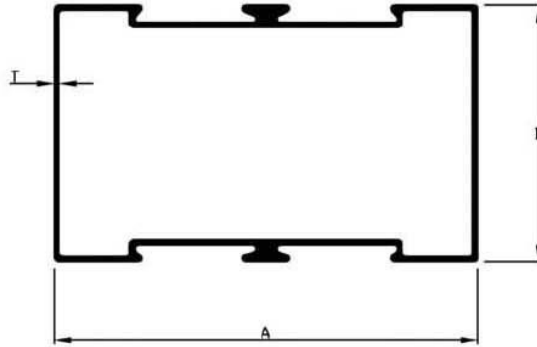

SEC.No.	C/L	A	B	T	WEIGHT
1121	16	50.00	25.00	0.75	1.900-2.100
1122	12	50.00	25.00	1.40	2.500-2.700
1123	15	63.00	38.00	0.84	2.500-2.700
1135	16	63.00	38.00	0.90	2.800-3.000
1131	16	63.00	38.00	1.05	3.000-3.300
1124	16	63.00	38.00	1.16	3.500-3.700
1125	16	63.00	38.00	1.27	3.800-4.100
1136	16	63.00	38.00	1.45	4.200-4.500
1126	16	63.00	38.00	1.60	4.800-5.000
1127	16	63.00	38.00	2.00	6.100-6.500
1133	16	63.00	38.00	2.50	7.600-8.000
1132	16	63.00	38.00	3.00	8.000-8.500
1128	15	101.0	44.45	1.20	4.650-4.800
1134	16	101.0	44.45	1.60	6.500-6.900
1129	16	101.0	44.45	1.90	7.700-7.900
1130	16	101.0	44.45	3.00	11.70-11.90

## DOOR MIDDLE SINGLE

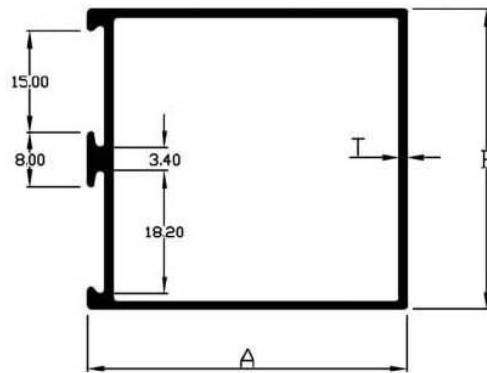

SEC.No.	C/L	A	B	T	WEIGHT
1161	12	47.50	44.45	1.15	2.200-2.350
1162	12	47.50	44.45	1.50	2.800-2.950
1163	12	47.50	44.45	2.00	3.600-3.750
1164	12	47.50	44.45	2.50	4.400-4.600
1165	12	83.50	44.45	1.45	3.800-4.000
1166	12	83.50	44.45	2.00	5.000-5.200

## DOOR MIDDLE DOUBLE

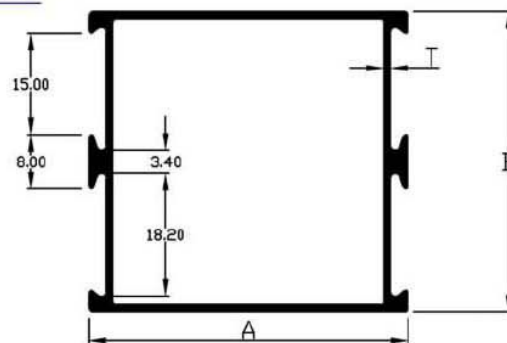

SEC.No.	C/L	A	B	T	WEIGHT
1180	12	47.50	44.45	0.90	1.900-2.200
1181	12	47.50	44.45	1.05	2.300-2.450
1187	16	47.50	44.45	1.50	3.700-4.000
1182	12	47.50	44.45	2.00	3.800-3.950
1183	12	47.50	44.45	2.55	4.600-4.800
1184	12	83.50	44.45	1.40	3.800-4.000
1185	12	83.50	44.45	2.00	5.200-5.400
1188	12	101.0	44.45	1.15	3.500-3.800
1190	12	101.0	44.45	1.50	4.800-5.200
1186	16	101.0	44.45	2.00	8.600-9.000
1189	16	101.0	44.45	3.00	11.00-13.00

## DOOR TOP

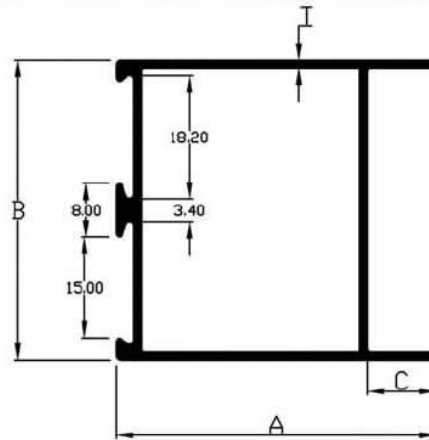

SEC.No.	C/L	A	B	C	T	WEIGHT
1201	15	47.50	44.45	10.15	1.15	2.500-2.700
1203	15	47.50	44.45	10.15	1.30	3.000-3.400
1202	15	47.50	44.45	10.15	2.50	4.400-4.600
1204	15	47.50	44.45	10.15	2.70	6.000-6.300

## DOOR TOP SINGLE LEG

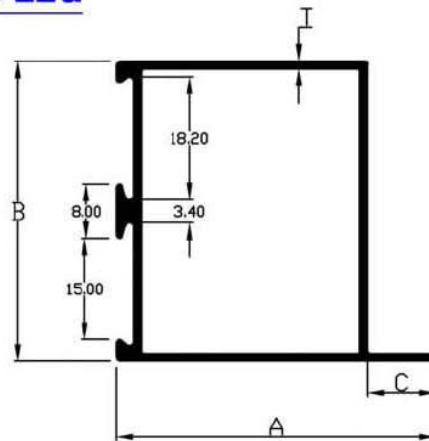

SEC.No.	C/L	A	B	C	T	WEIGHT
1221	12	47.50	44.45	10.15	1.15	2.100-2.300
1222	12	47.50	44.45	10.15	1.25	2.300-2.500
1223	12	47.50	44.45	10.15	1.60	2.800-3.000

## DOOR BOTTOM

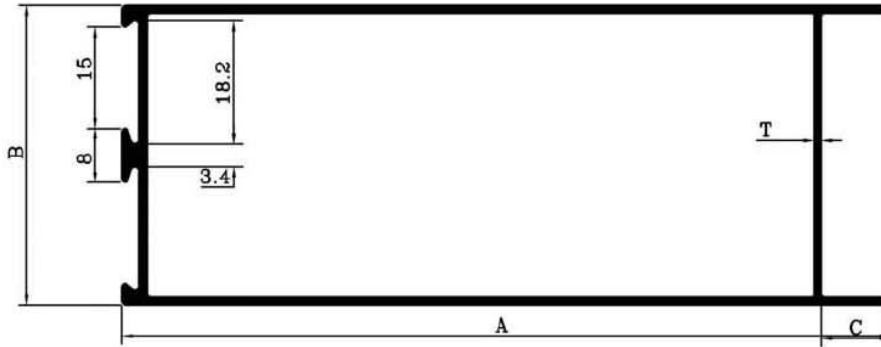

SEC.No.	C/L	A	B	C	T	WEIGHT
1240	12	83.50	44.45	9.50	1.20	3.200-3.500
1241	12	83.50	44.45	9.50	1.50	3.900-4.100
1242	12	83.50	44.45	9.50	2.00	5.000-5.300
1243	12	83.50	44.45	9.50	3.00	7.300-7.500
1249	16	101.00	44.45	25.40	1.15	4.500-5.000
1251	16	101.00	44.45	25.40	1.25	4.800-5.200
1250	16	101.00	44.45	25.40	3.00	12.00-14.00
1244	12	114.30	44.45	10.10	1.20	3.900-4.100
1245	12	114.30	44.45	10.10	1.50	4.800-5.000
1246	12	114.30	44.45	10.10	3.00	9.100-9.500
1247	16	114.30	44.45	25.40	1.50	6.400-6.600
1248	16	114.30	44.45	25.40	2.50	10.300-10.500

## DOOR VERTICAL

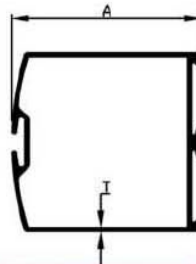

SEC.No.	C/L	A	B	T	WEIGHT
1261	14	47.50	44.45	1.24	3.000-3.200
1266	14	47.50	44.45	1.50	3.700-4.000
1264	14	47.50	44.45	2.00	2.600-2.800
1262	14	47.50	44.45	2.19	4.800-5.000
1267	14	47.50	44.45	2.50	5.200-5.500
1269	14	47.50	44.45	3.00	6.000-6.500
1265	14	83.50	44.45	1.35	4.500-4.700
1263	14	83.50	44.45	2.00	6.100-6.300
1268	14	83.50	44.45	3.00	9.000-9.500



## GLAZING CLIP

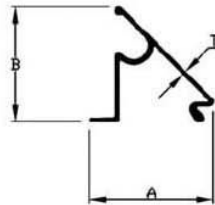

SEC.No.	C/L	A	B	T	WEIGHT
1280	12	18.40	17.00	0.52	0.240-0.260
1281	12	18.40	17.00	0.60	0.260-0.280
1282	12	18.40	17.00	0.65	0.280-0.320
1283	12	18.40	17.00	0.75	0.350-0.380

## GLAZING PLATE

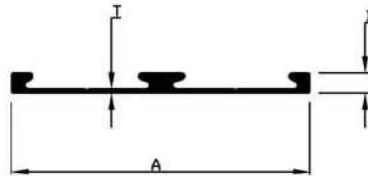

SEC.No.	C/L	A	B	T	WEIGHT
1291	12	44.00	3.40	0.69	0.500-0.600
1292	12	44.00	3.40	0.78	0.600-0.700

### GLASS SEC. 12.0 mm SOLID

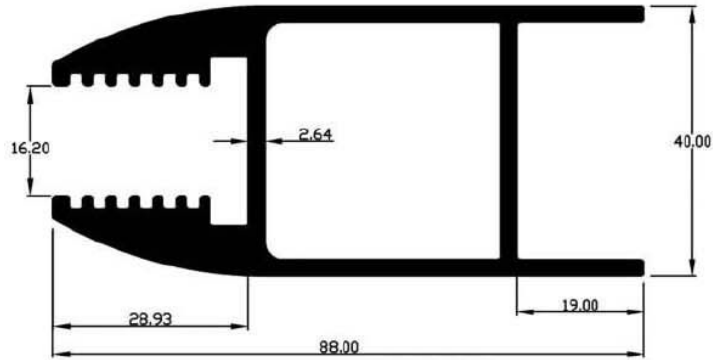

SEC.No.	C/L	A	B	T	WEIGHT
1302	15	88.00	40.00	1.70	8.000-8.400
1301	15	88.00	40.00	2.64	10.800-11.000

### SAMOSA SEC.

SEC. NO:-1311

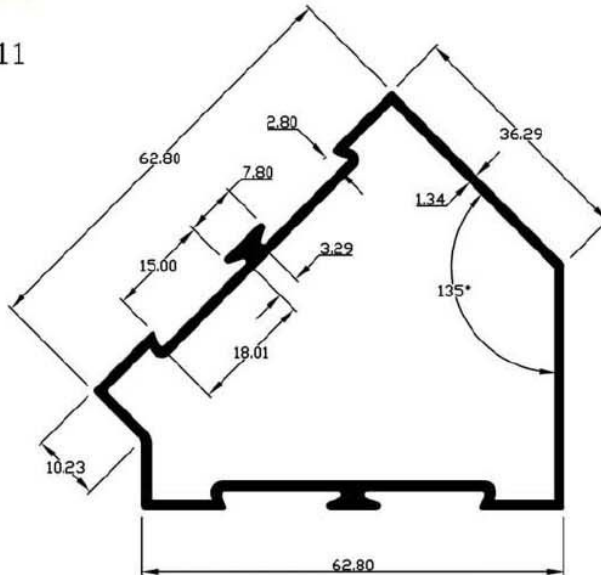

WEIGHT:- 2.800-3.000 kg/12'

## CURTAIN WALL

SEC. NO: -1316

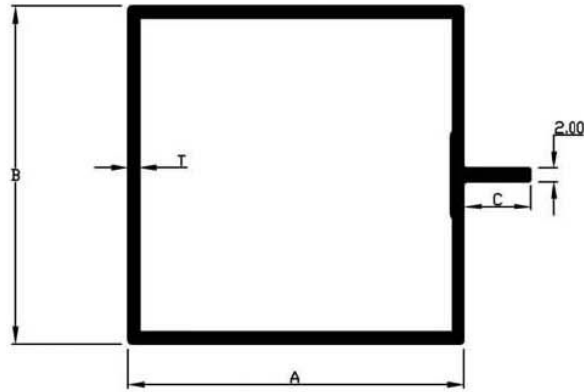

SEC.No.	C/L	A	B	C	T	WEIGHT
1317	16	50.00	50.00	10.00	1.10	3.300-3.500
1316	16	50.00	50.00	5.00	1.15	3.300-3.500
1318	16	50.00	50.00	5.00	1.30	3.800-4.100

## CURTAIN WALL

SEC. NO: -1321

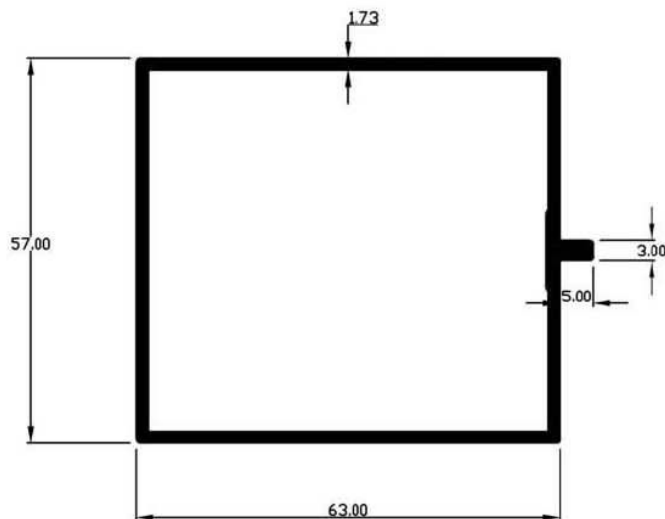

WEIGHT: - 5.500-5.700 kg/16'

### 3/4" TWO TRACK TOP

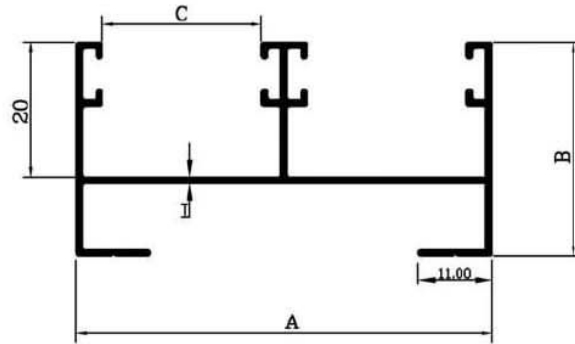

SEC.No.	C/L	A	B	C	T	WEIGHT
1331	12	61.85	31.75	23.68	0.65	1.200-1.400
1332	12	61.85	31.75	23.68	0.75	1.400-1.600
1333	12	61.85	31.75	23.68	0.84	1.600-1.800
1334	12	61.85	31.75	23.68	0.94	1.800-2.000
1335	12	61.85	31.75	23.68	1.04	2.000-2.200
1336	12	61.85	31.75	23.68	1.14	2.200-2.500
1337	12	61.85	31.75	23.68	1.40	2.700-2.900

### 3/4" TWO TRACK BOTTOM

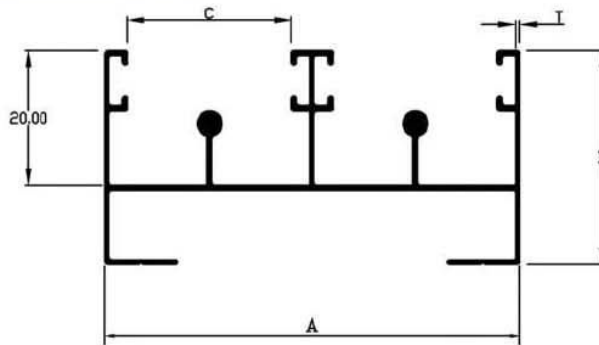

SEC.No.	C/L	A	B	C	T	WEIGHT
1351	12	61.85	31.75	24.50	0.65	1.500-1.700
1352	12	61.85	31.75	24.50	0.85	1.700-1.900
1353	12	61.85	31.75	24.50	1.00	2.000-2.200
1354	12	61.85	31.75	24.50	1.10	2.200-2.500
1355	12	61.85	31.75	24.50	1.37	3.000-3.350
1356	12	61.85	31.75	24.50	1.55	3.100-3.400

### 3/4" THREE TRACK TOP

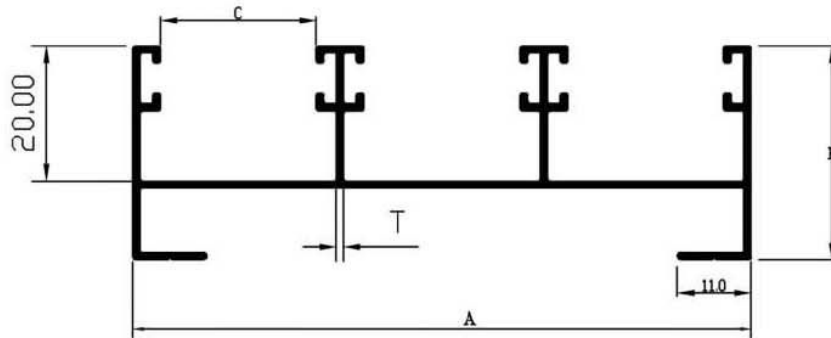

SEC.No.	C/L	A	B	C	T	WEIGHT
1371	12	92.0	31.75	23.20	0.65	1.800-2.000
1372	12	92.0	31.75	23.20	0.72	2.000-2.200
1373	12	92.0	31.75	23.20	0.87	2.400-2.600
1374	12	92.0	31.75	23.20	0.98	2.700-3.000
1375	12	92.0	31.75	23.20	1.30	3.400-3.600
1376	12	92.0	31.75	23.20	1.50	3.700-3.900
1377	12	92.0	31.75	23.20	2.00	4.500-4.900

### 3/4" THREE TRACK BOTTOM

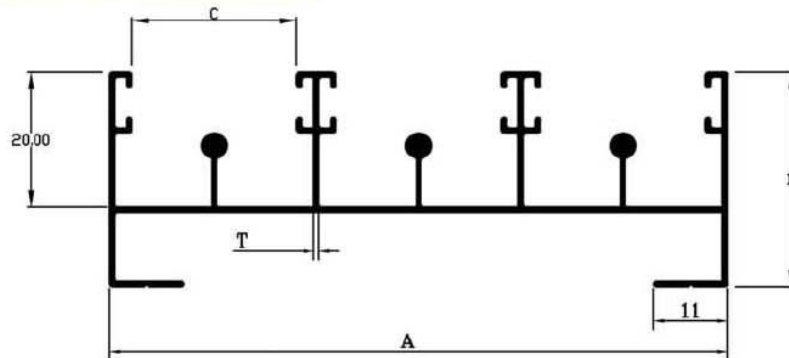

SEC.No.	C/L	A	B	C	T	WEIGHT
1391	12	92.00	31.75	24.50	0.75	2.500-2.750
1392	12	92.00	31.75	24.50	0.89	2.800-3.000
1393	12	92.00	31.75	24.50	1.10	3.200-3.400
1394	12	92.00	31.75	24.50	1.30	3.900-4.100
1395	12	92.00	31.75	24.50	1.50	4.500-4.700
1396	12	92.00	31.75	24.50	2.00	5.300-5.700

### 3/4" FOUR TRACK TOP

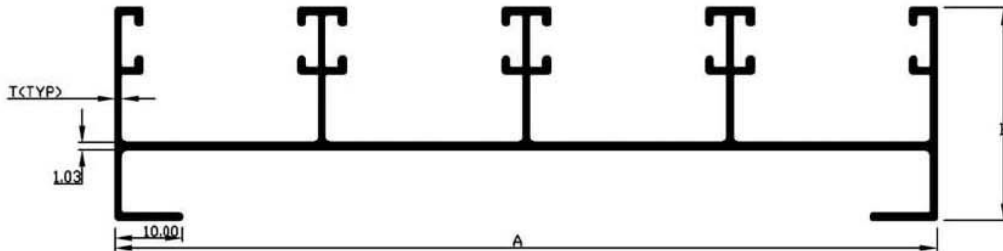

SEC.No.	A	B	T	Wt.(kg/Mtr.)	Wt.(kg/12')
1411	122.40	31.50	0.97	0.901	3.300-3.600
1412	122.40	31.50	1.30	1.142	4.180-4.500
1413	122.40	31.50	1.50	1.585	4.800-5.100

### 3/4" FOUR TRACK BOTTOM

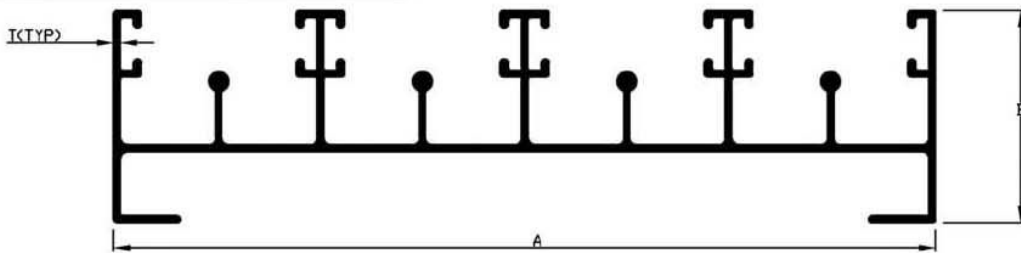

SEC.No.	A	B	T	Wt.(kg/Mtr.)	Wt.(kg/12')
1421	122.40	31.50	1.00	0.928	4.000-4.500
1422	122.40	31.50	1.30	1.321	4.800-5.200
1423	122.40	31.50	1.50	1.580	5.800-6.200

### 3/4" FOUR TRACK BOTTOM

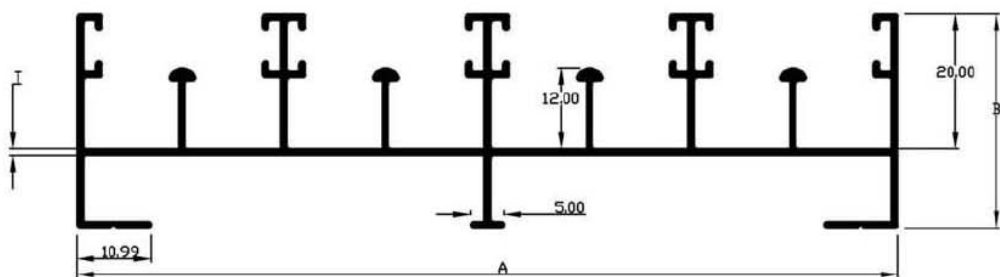

SEC.No.	A	B	T	Wt.(kg/Mtr.)	Wt.(kg/12')
1431	122.40	31.50	1.00	0.928	3.850-4.200
1432	122.40	31.50	1.30	1.377	5.000-5.400
1433	122.40	31.50	1.50	1.580	5.800-6.200

SEC. NO:- 1441

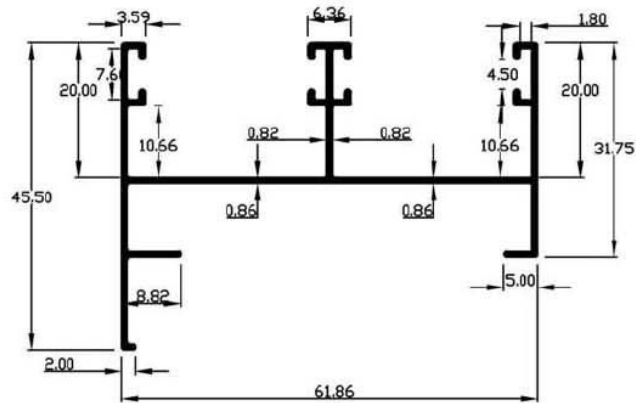

AREA:- 173.773 Sqmm<sup>^</sup>

WEIGHT:- 1.717 kg/12'

SEC. NO:- 1446

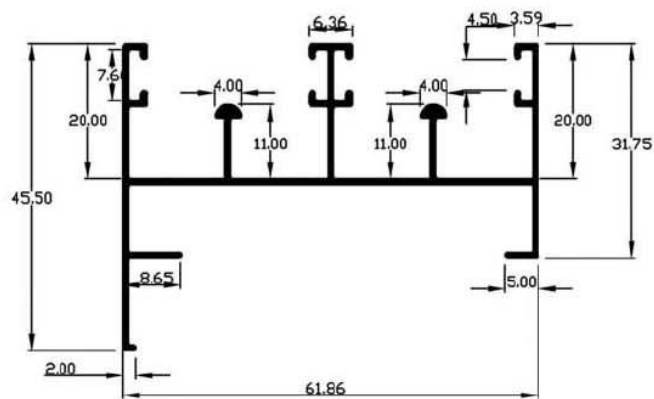

AREA:- 201.398 Sqmm<sup>^</sup>

WEIGHT:- 2.000 kg/12'

### 3/4" TWO TRACK BOTTOM (HOLLOW)

SEC. NO:-1451

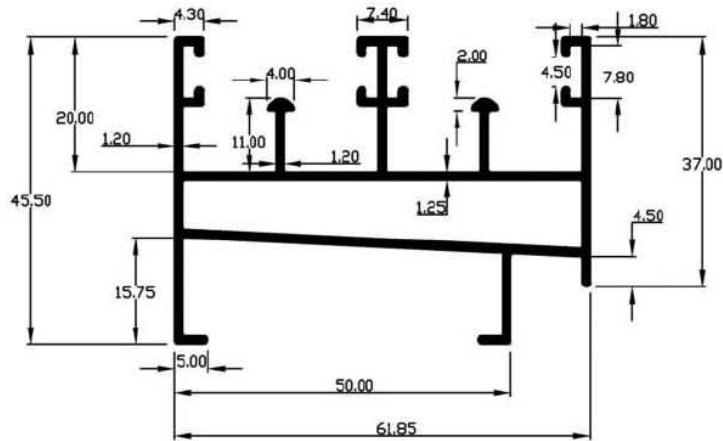

WEIGHT:- 3.700-3.900 kg/12'

### 3/4" THREE TRACK BOTTOM (HOLLOW)

SEC. NO:-1456

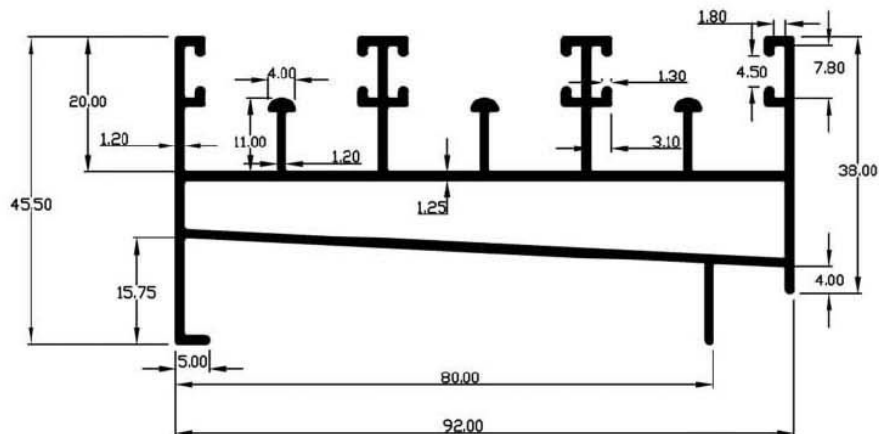

WEIGHT:- 5.000-5.400 kg/12'



### 3/4" HANDLE

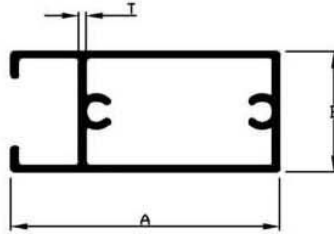

SEC.No.	C/L	A	B	T	WEIGHT
1461	16	40.00	18.00	0.70	1.300-1.500
1462	16	40.00	18.00	0.95	1.750-1.950
1463	12	40.00	18.00	1.20	1.500-1.700
1464	16	40.00	18.00	1.50	2.500-2.700
1465	16	40.00	18.00	1.80	3.000-3.300

### 3/4" INTERLOCK

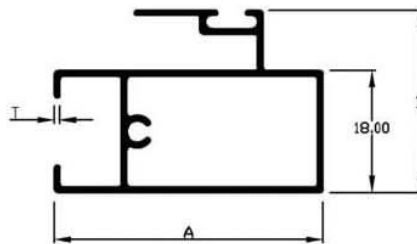

SEC.No.	C/L	A	B	T	WEIGHT
1491	16	40.00	27.00	0.71	1.450-1.650
1492	16	40.00	27.00	0.84	1.750-1.950
1493	12	40.00	27.00	1.20	1.900-2.100
1494	16	40.00	27.00	1.50	3.100-3.300
1495	16	40.00	27.00	1.80	3.500-3.800

### 3/4" TOP BOTTOM

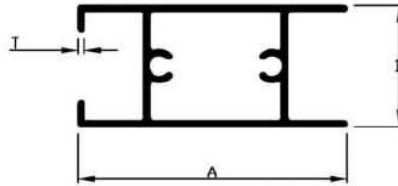

SEC.No.	C/L	A	B	T	WEIGHT
1511	16	40.00	18.00	0.70	1.300-1.450
1512	16	40.00	18.00	0.87	1.700-1.850
1513	16	40.00	18.00	1.50	2.600-2.800
1514	16	40.00	18.00	1.80	3.000-3.300

### BEARING BOTTOM

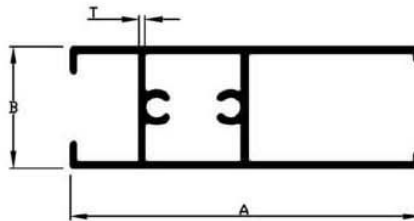

SEC.No.	C/L	A	B	T	WEIGHT
1530	12	52.00	18.00	0.70	1.100-1.400
1531	12	52.00	18.00	0.90	1.400-1.600

### MATTING

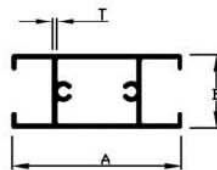

SEC.No.	C/L	A	B	T	WEIGHT
1540	16	42.00	18.00	0.75	1.500-1.600
1542	12	42.00	18.00	0.90	1.050-1.250
1541	12	42.00	18.00	1.16	1.500-1.700

## SINTEX - " A "

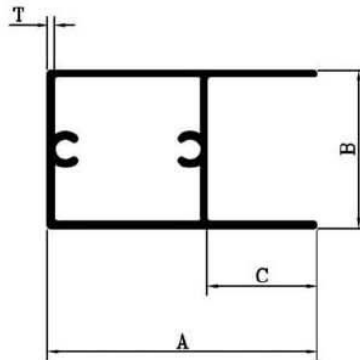

SEC.No.	C/L	A	B	C	T	WT. RANGE
1551	16'	40.00	23.60	16.30	1.00	1.800-2.000

## SINTEX - " H "

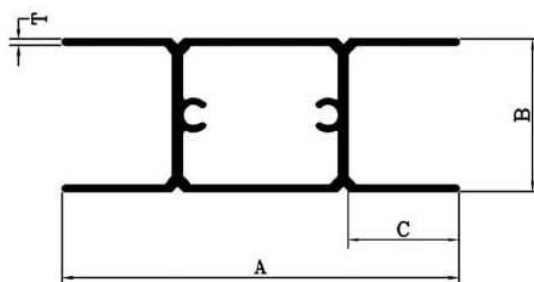

SEC.No.	C/L	A	B	C	T	WT. RANGE
1556	12'	60.00	23.00	16.50	0.84	1.500-1.700

## 20 mm TWO TRACK TOP

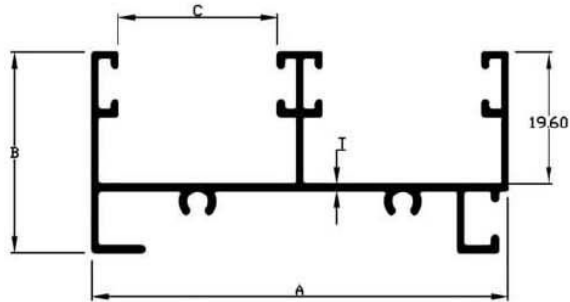

SEC.No.	C/L	A	B	C	T	WEIGHT
1560	16	62.00	29.50	23.80	0.70	2.100-2.200
1561	16	62.00	29.50	23.80	0.85	2.400-2.600
1562	16	62.00	29.50	23.40	1.10	2.800-3.000
1563	16	62.00	29.50	23.80	1.50	4.000-4.200
1564	16	62.00	29.50	23.80	1.65	4.500-4.800
1565	16	62.00	29.50	23.80	2.00	4.800-5.000

## 20 mm TWO TRACK BOTTOM

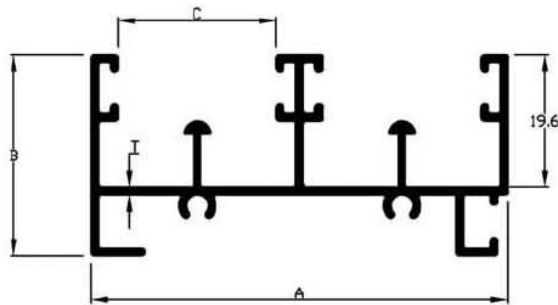

SEC.No.	C/L	A	B	C	T	WEIGHT
1581	16	62.00	29.50	23.80	0.80	2.450-2.650
1582	16	62.00	29.50	23.40	1.05	2.800-3.100
1583	16	62.00	29.50	23.80	1.50	4.500-4.900
1584	16	62.00	29.50	23.80	1.65	5.000-5.500
1585	16	62.00	29.50	23.80	2.00	5.300-5.800

## 20 mm THREE TRACK TOP

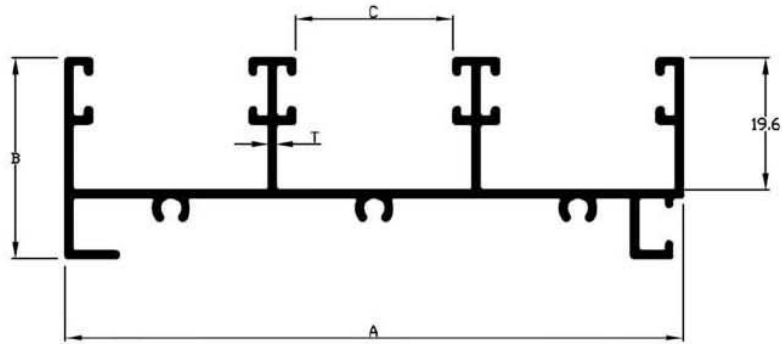

SEC.No.	C/L	A	B	C	T	WEIGHT
1600	16	92.00	29.50	23.50	0.72	3.100-3.400
1601	16	92.00	29.50	23.50	0.95	3.600-3.800
1603	16	92.00	29.50	22.70	1.10	4.100-4.400
1602	16	92.00	29.50	22.13	1.50	5.200-5.600

## 20 mm THREE TRACK BOTTOM

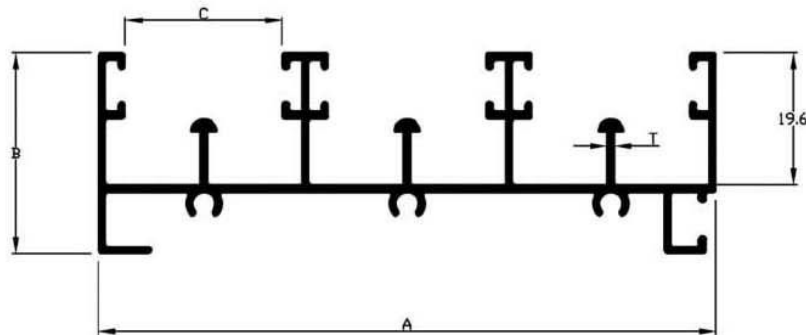

SEC.No.	C/L	A	B	C	T	WEIGHT
1620	16	92.00	29.50	23.50	0.70	3.300-3.800
1621	16	92.00	29.50	23.50	0.95	3.800-4.000
1623	16	92.00	29.50	22.70	1.10	4.400-4.700
1622	16	92.00	29.50	22.13	1.50	6.000-6.500

## 20 mm FOUR TRACK TOP

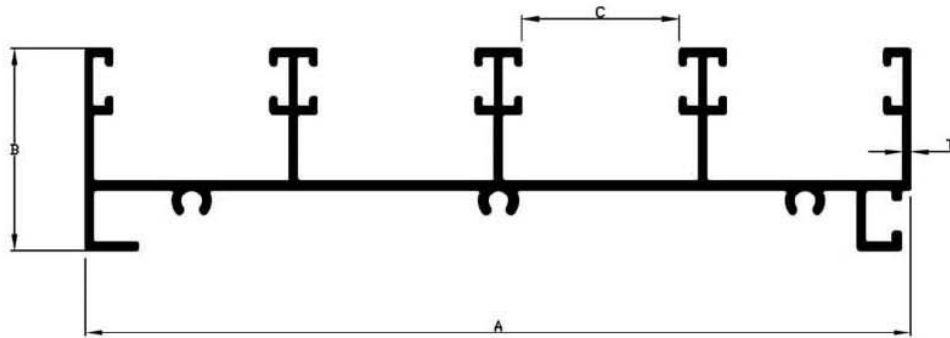

SEC.No.	C/L	A	B	C	T	WEIGHT
1631	16	123.0	30.00	23.35	1.27	5.650-5.850

## 20 mm FOUR TRACK BOTTOM

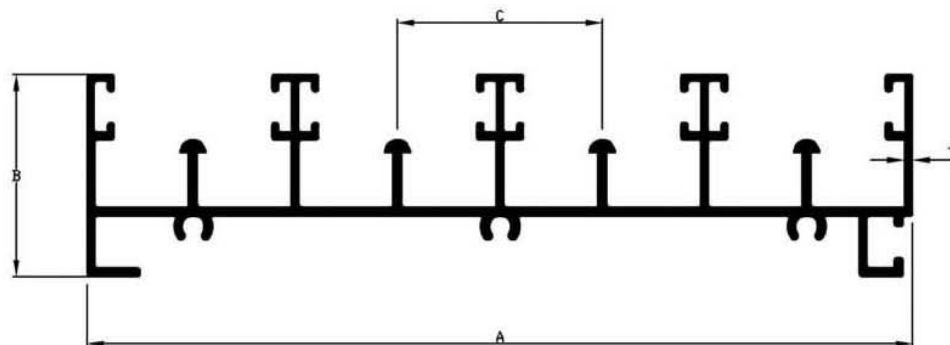

SEC.No.	C/L	A	B	C	T	WEIGHT
1636	16	123.0	30.00	30.45	1.27	6.550-6.750

## 20mm HANDLE

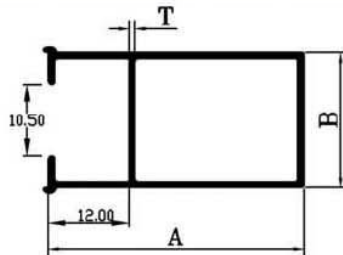

SEC.No.	C/L	A	B	T	WEIGHT
1641	12	38.00	20.00	0.92	1.100-1.300
1642	12	38.00	20.00	1.00	1.200-1.400
1645	12	38.00	20.00	1.20	1.500-1.700
1643	12	38.00	20.00	1.50	1.700-1.900
1644	12	38.00	20.00	1.65	1.900-2.100

## 20mm INTERLOCK

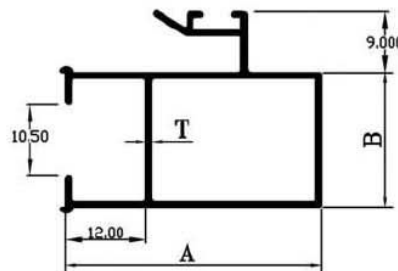

SEC.No.	C/L	A	B	T	WEIGHT
1651	12	38.00	20.00	0.82	1.200-1.400
1655	12	38.00	20.00	1.00	1.400-1.600
1652	12	38.00	20.00	1.20	1.700-1.900
1653	12	38.00	20.00	1.50	2.000-2.200
1654	12	38.00	20.00	1.65	2.300-2.500

## 20mm TOP BOTTOM

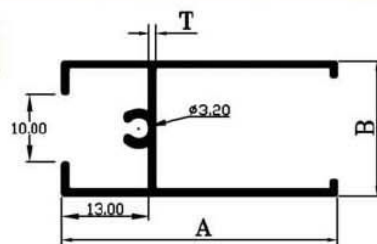

SEC.No.	C/L	A	B	T	WEIGHT
1661	12	41.00	20.00	0.85	1.000-1.200
1665	12	41.00	20.00	1.00	1.200-1.400
1663	12	41.00	20.00	1.20	1.400-1.600
1662	12	41.00	20.00	1.50	1.700-1.900
1664	12	41.00	20.00	1.65	2.000-2.300

### 1" TWO TRACK TOP

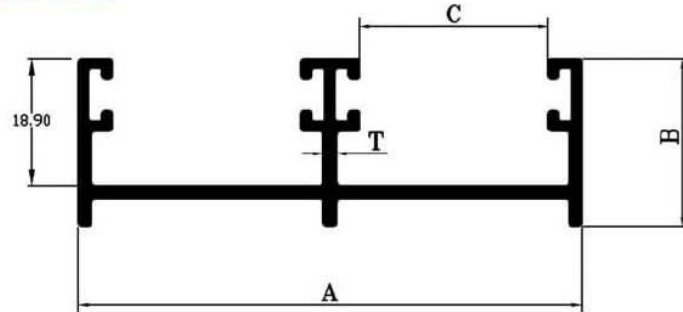

SEC.No.	C/L	A	B	C	T	WEIGHT
1671	12	75.00	25.00	28.20	2.00	3.300-3.500

### 1" TWO TRACK BOTTOM

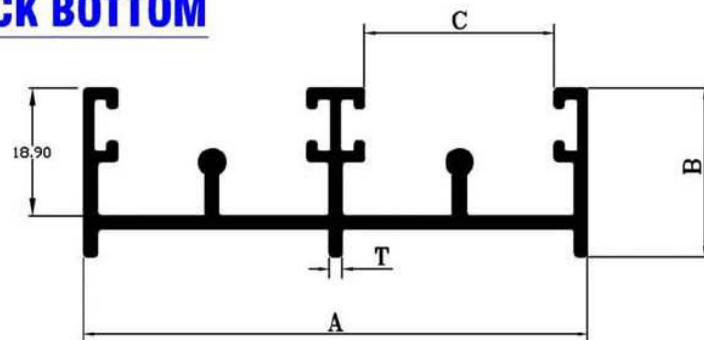

SEC.No.	C/L	A	B	C	T	WEIGHT
1681	12	75.00	25.00	28.20	2.00	3.800-4.000

### 1" TWO TRACK BOTTOM HOLLOW

SEC. NO:- 1691

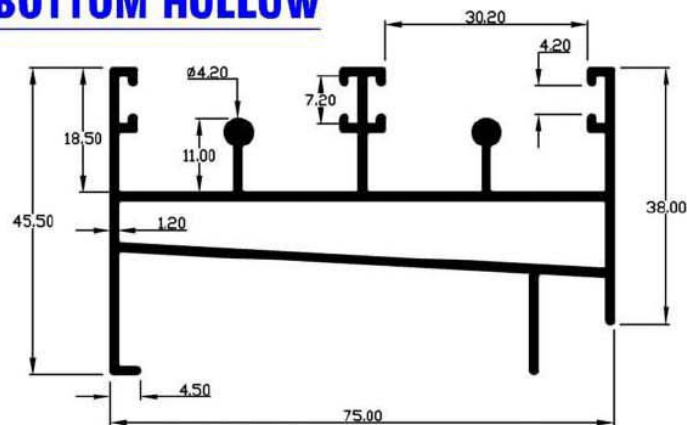

WEIGHT: 4.000-4.300 kg/12'



### 1" THREE TRACK TOP

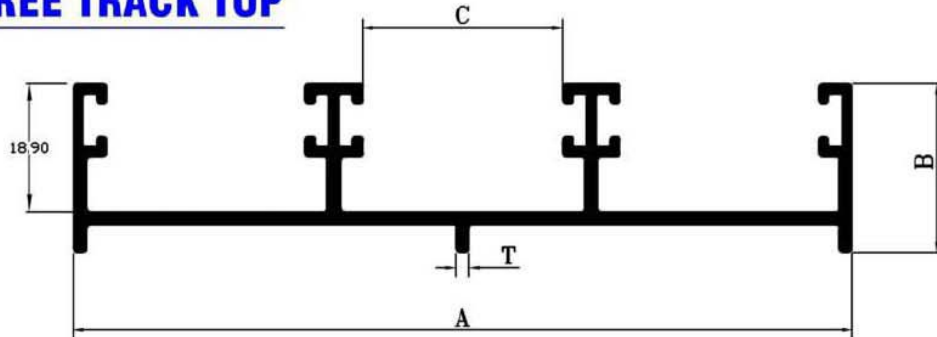

SEC.No.	C/L	A	B	C	T	WEIGHT
1702	12	116.0	25.00	29.70	1.45	3.700-4.000
1701	12	116.0	25.00	29.70	2.00	4.700-5.000

### 1" THREE TRACK BOTTOM

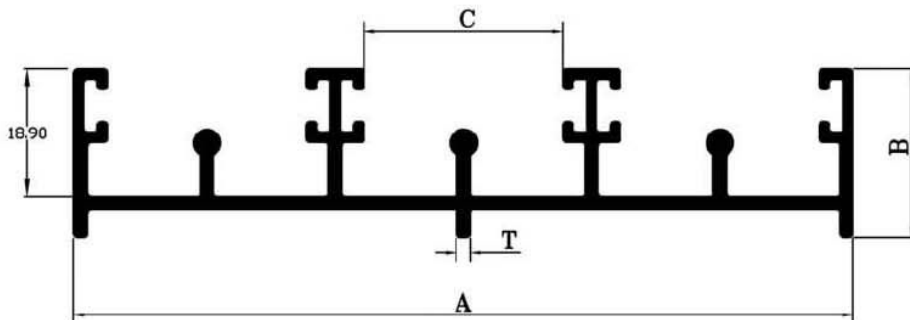

SEC.No.	C/L	A	B	C	T	WEIGHT
1712	12	116.0	25.00	29.60	1.47	4.500-4.800
1711	12	116.0	25.00	29.60	2.00	5.500-5.800

### 1" THREE TRACK BOTTOM HOLLOW

SEC. NO:- 1721

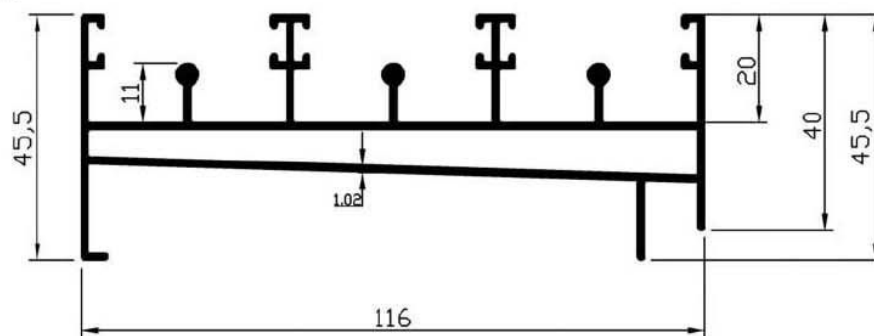

WEIGHT: 5.800-6.200 kg/12'

## SINGLE GLASS CHANNEL

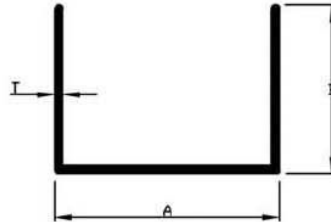

SEC.No.	C/L	A	B	T	WEIGHT
2301	12	9.52	9.52	0.52	0.140-0.170
2302	12	9.52	9.52	0.72	0.180-0.220
2303	12	12.50	12.50	0.55	0.180-0.220
2306	12	12.50	12.50	0.65	0.220-0.250
2304	12	28.40	25.00	1.20	0.900-9.500
2305	12	33.40	25.00	1.20	0.950-1.000

## SEC.No.-2251

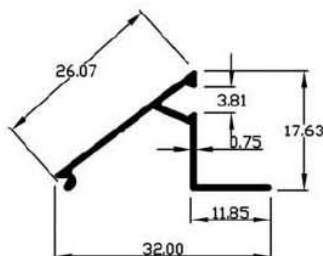

WEIGHT: -0.450-0.480 kg/12'

## 1" HANDLE

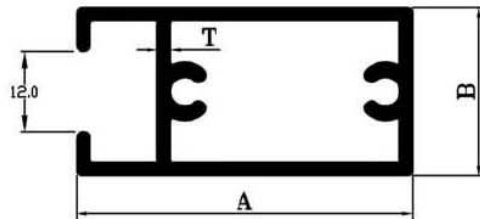

SEC.No.	C/L	A	B	T	WEIGHT
1740	15	44.00	25.40	0.82	1.700-2.000
1741	15	50.00	25.00	0.85	1.800-2.100
1742	12	50.00	25.00	1.20	2.100-2.300
1743	12	50.00	25.00	1.30	2.260-2.400
1744	12	50.00	25.00	1.40	2.400-2.600
1745	12	50.00	25.00	1.50	2.600-2.800
1746	12	50.00	25.00	2.00	3.400-3.700

## 1" INTERLOCK

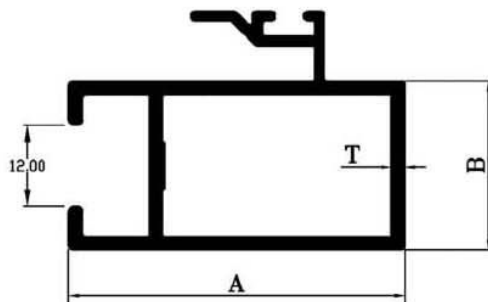

SEC.No.	C/L	A	B	T	WEIGHT
1760	12	50.00	25.00	0.75	1.600-1.900
1765	12	50.00	25.00	1.12	2.150-2.250
1761	12	50.00	25.00	1.20	2.300-2.400
1762	12	50.00	25.00	1.30	2.400-2.600
1763	12	50.00	25.00	1.50	2.800-3.100
1764	12	50.00	25.00	2.00	3.500-3.750

## 1" TOP BOTTOM

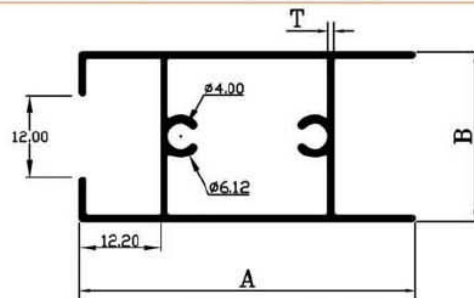

SEC.No.	C/L	A	B	T	WEIGHT
1783	15	50.00	25.40	0.82	1.700-2.000
1781	15	50.00	25.00	0.85	1.800-2.100
1782	15	50.00	25.00	1.00	2.200-2.500
1780	15	45.00	25.00	1.10	2.300-2.500

## BEARING BOTTOM

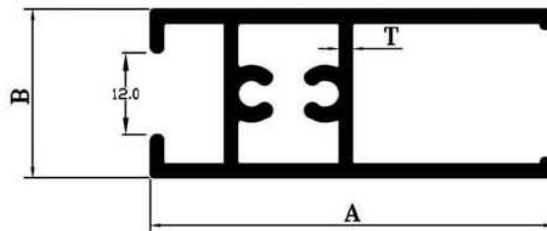

SEC.No.	C/L	A	B	T	WEIGHT
1791	12	60.00	25.00	1.01	2.400-2.600
1792	12	60.00	25.00	1.32	2.600-2.800
1793	12	60.00	25.00	2.00	3.800-4.100

## MATTING

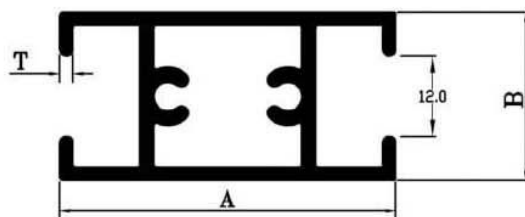

SEC.No.	C/L	A	B	T	WEIGHT
1801	12	50.00	25.00	0.85	1.600-1.800
1802	12	50.00	25.00	1.10	1.900-2.150
1803	12	50.00	25.00	1.30	2.300-2.500
1804	12	50.00	25.00	1.50	2.700-2.900
1805	12	50.00	25.00	2.00	3.500-3.750

SEC.No.-1821

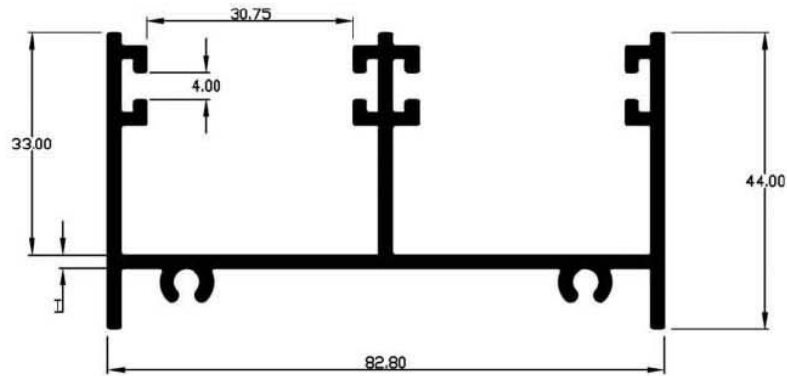

SEC.No.	C/L	T	WEIGHT
1822	12	1.30	3.400-3.800
1821	12	2.00	5.000-5.400

SEC.No.-1831

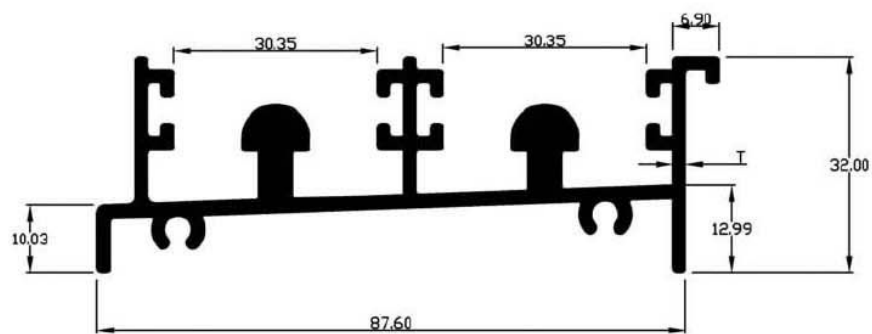

SEC.No.	C/L	T	WEIGHT
1832	12	1.40	4.600-5.000
1831	12	1.90	6.400-6.800

SEC.No.-1841

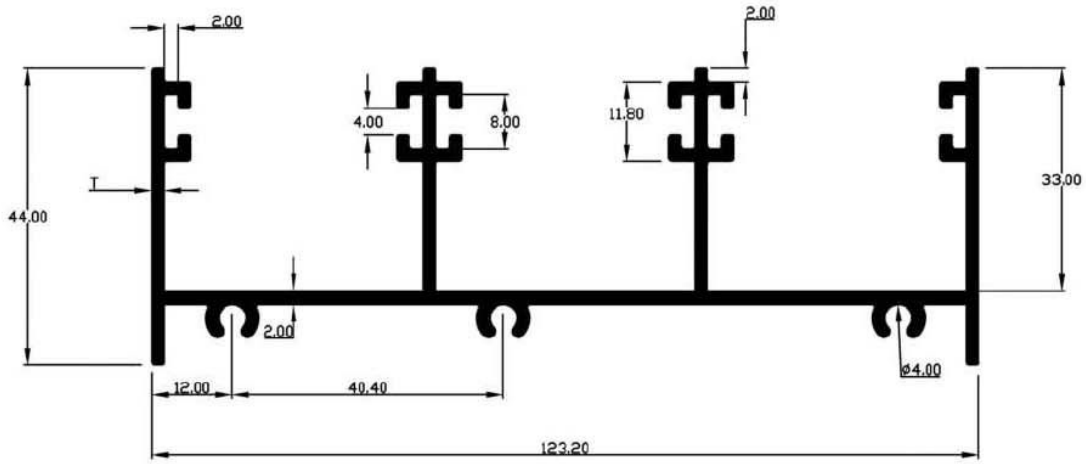

SEC.No.	C/L	T	WEIGHT
1841	12	1.90	7.000-7.500
1842	12	1.33	5.000-5.500
1843	12	1.20	4.500-5.000

SEC.No.-1851

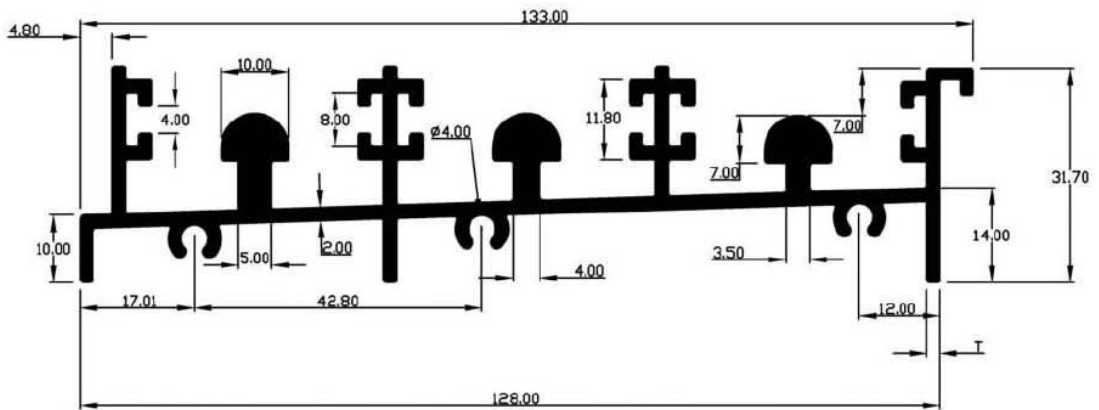

SEC.No.	C/L	T	WEIGHT
1851	12	1.90	9.000-9.500
1852	12	1.40	7.400-7.700
1853	12	1.20	6.600-7.100

SEC. NO:- 1856

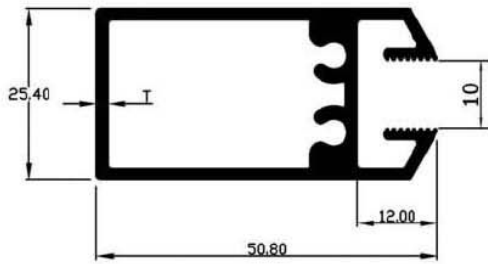

SEC.No.	C/L	T	WEIGHT
1857	12	1.00	2.500-2.800
1856	12	1.70	3.200-3.400

SEC. NO:- 1861

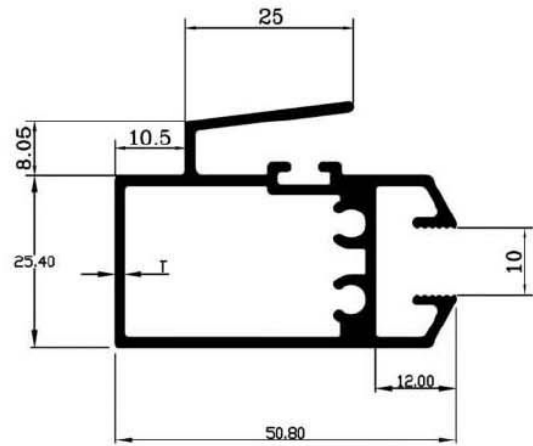

SEC.No.	C/L	T	WEIGHT
1862	12	1.30	3.100-3.300
1861	12	1.40	3.300-3.500

SEC. NO:- 1866

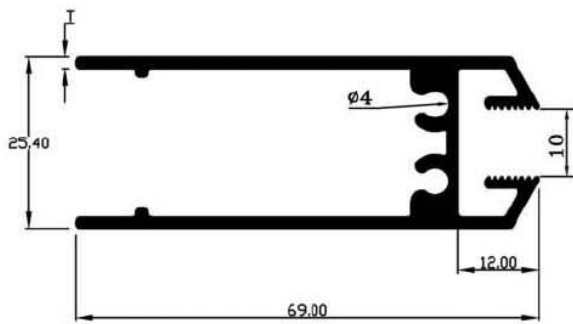

SEC.No.	C/L	T	WEIGHT
1867	12	1.35	3.000-3.200
1866	12	1.70	3.500-3.700

SEC. NO:- 1871

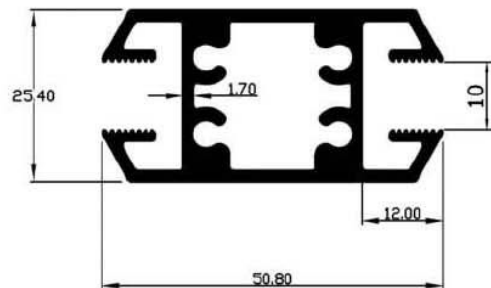

WEIGHT: 4.100-4.300 kg/12'

SEC.No.- 1876

**60 X 18 HANDLE**

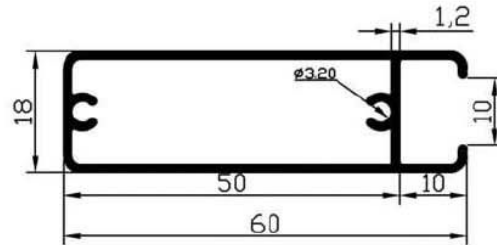

WEIGHT:- 2.000 kg/12'

SEC.No.- 1881

**60 X 18 INTERLOCK**

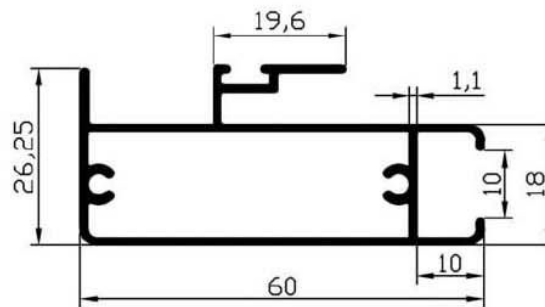

WEIGHT:- 2.350 kg/12'

SEC.No.- 1886

**60 X 18 TOP BOTTOM**

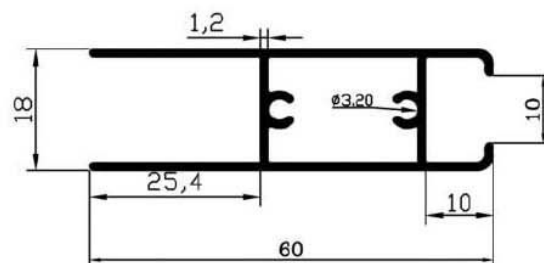

WEIGHT:- 2.000 kg/12'



## L-TUBE

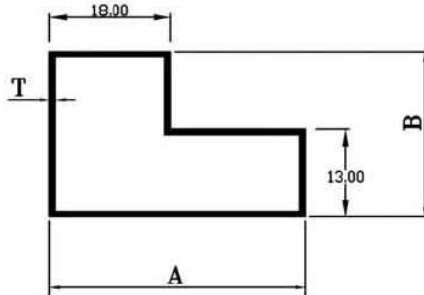

SEC.No.	C/L	A	B	T	WEIGHT
1891	12	38.00	24.50	0.85	0.950-1.050
1892	12	38.00	24.50	0.90	1.050-1.150
1894	12	38.00	25.00	1.45	1.700-1.900
1893	12	50.00	25.00	1.10	1.300-1.500

## 'L' TUBE WITH GROOVE

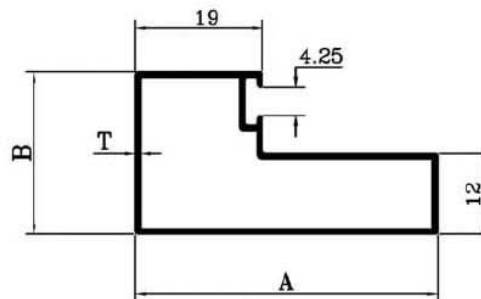

SEC.No.	C/L	A	B	T	WEIGHT
1901	12	45.00	24.00	0.82	1.100-1.300
1902	12	45.00	24.00	1.10	1.500-1.700
1903	12	45.00	24.00	1.50	2.000-2.300

## 2 1/2 X 1 1/2 L-TUBE

### **SEC.No.-1911**

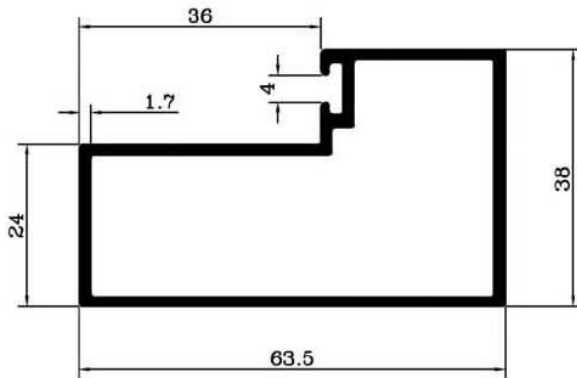

WEIGHT: -4.000 kg/16'

### **MOULDING CHOKHAT**

### **SEC.No.-1912**

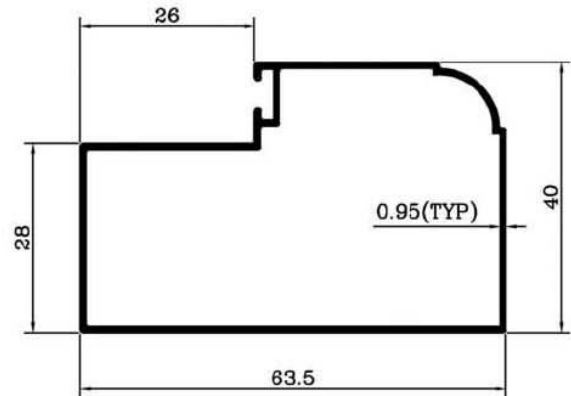

WEIGHT: -2.650-2.850kg/16'

### **CORNER PARTITION**

### **SEC.No.-1913**

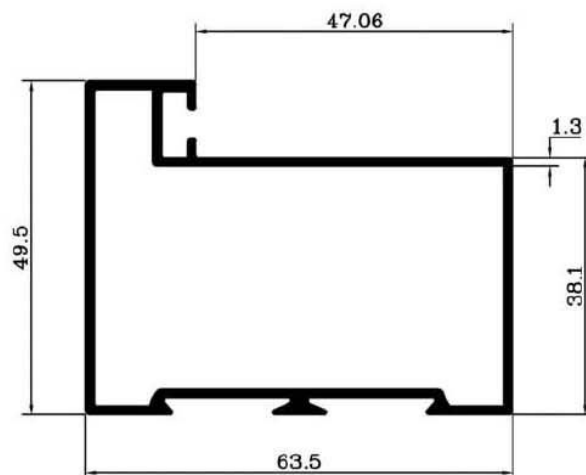

WEIGHT: -3.700-4.000 kg/16'

## CURTAIN WALL

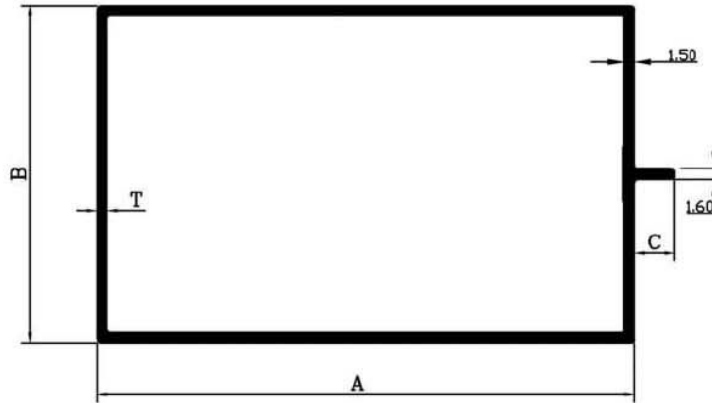

SEC.No.	C/L	A	B	C	T	WT. RANGE
1921	15'	80.00	50.00	6.000	1.50	4.800-5.100

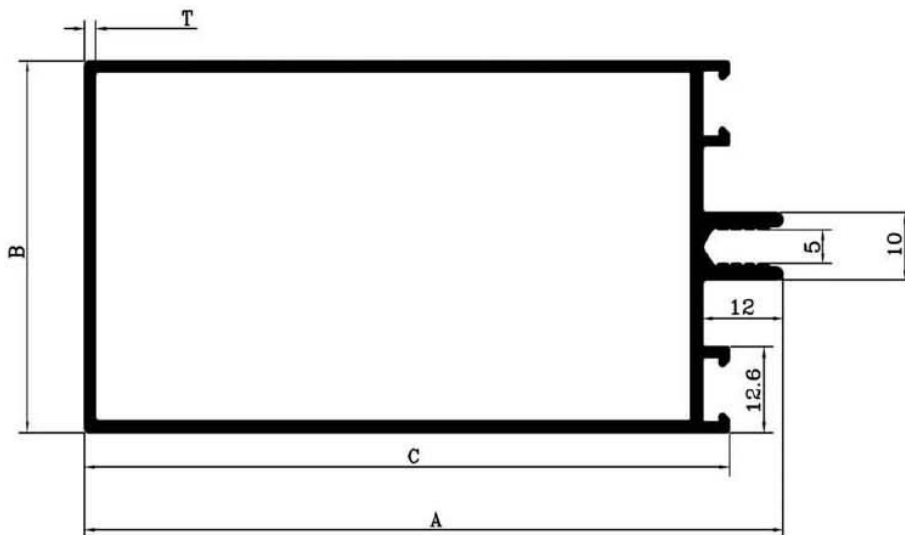

SEC.No.	C/L	A	B	C	T	WT. RANGE
1931	16'	104.0	55.00	96.00	1.70	7.500-8.500
1932	16'	104.0	55.00	96.00	2.00	8.500-9.500
1933	16'	75.0	55.00	67.00	1.70	6.200-6.800

## COVER PLATE

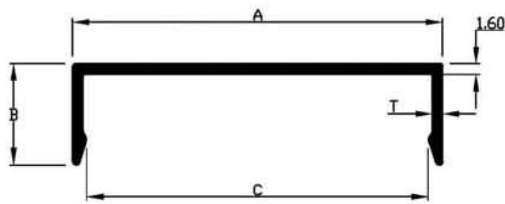

SEC.No.	C/L	A	B	C	T	WT. RANGE
1936	15'	55.00	15.00	50.85	1.45	1.500-1.700

## PRESSURE PLATE

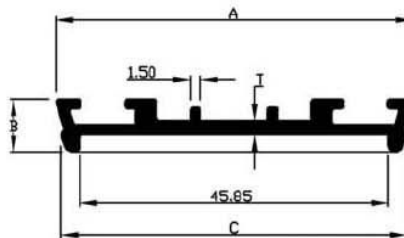

SEC.No.	C/L	A	B	C	T	WT. RANGE
1941	15'	53.00	8.000	51.35	2.10	1.900-2.100

SEC. NO:-1946

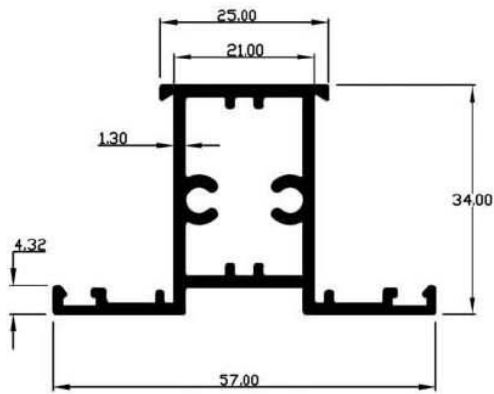

WEIGHT:- 2.100-2.400 kg/12'

SEC. NO:-1951

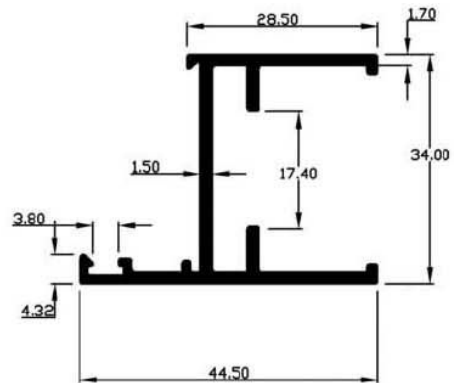

WEIGHT:- 2.100-2.300 kg/12'

SEC. NO:- 1956

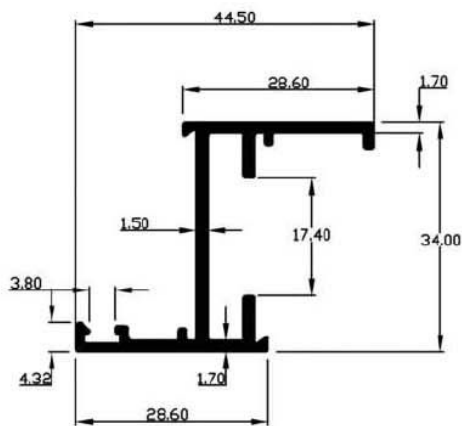

WEIGHT:- 1.500-1.800 kg/12'

SEC. NO:- 1961

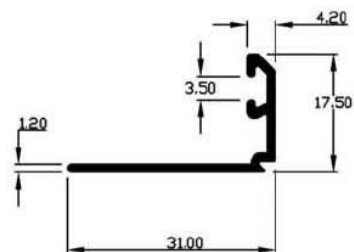

WEIGHT:- 0.650-0.700 kg/12'

SEC. NO:- 1966

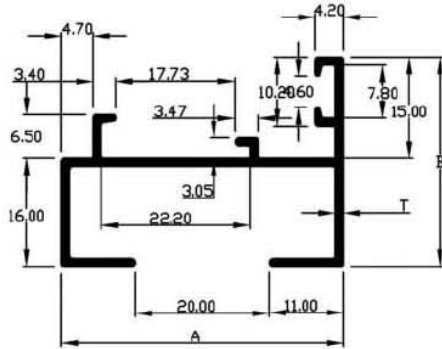

SEC.No.	A	B	T	Wt.(kg/12')
1966	42.00	31.00	1.20	1.500-1.800
1967	42.00	31.00	1.50	1.800-2.100

SEC. NO:- 1971

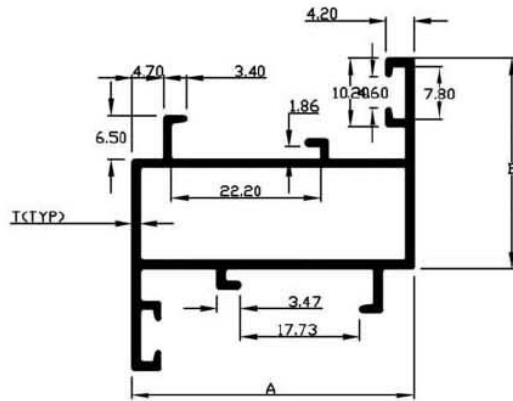

SEC.No.	A	B	T	Wt.(kg/12')
1971	42.00	31.20	1.20	2.200-2.400
1972	42.00	31.20	1.50	2.650-2.950

SEC. NO:- 1976

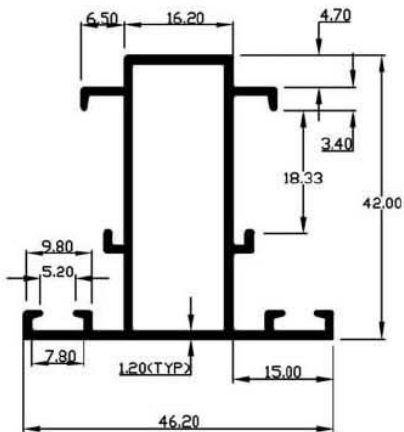

SEC.No.	A	B	T	Wt.(kg/12')
1976	46.20	42.00	1.20	2.190-2.390
1977	46.20	42.00	1.50	2.650-2.950

SEC. NO:- 1981

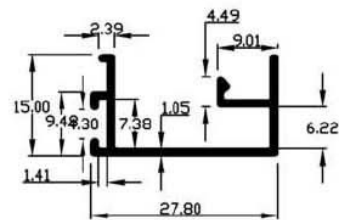

SEC.No.	A	B	T	Wt.(kg/12')
1981	27.80	15.00	1.05	0.770-0.870
1982	27.80	15.00	1.50	1.000-1.200

### MULLION 40 mm SERIES

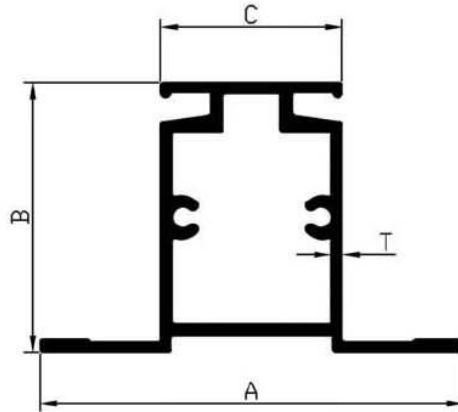

SEC.No.	C/L	A	B	C	T	WT. RANGE
1985	12'	63.00	40.00	27.00	1.40	2.700-3.000
1986	12'	63.00	40.00	27.00	1.70	3.300-3.500

### SHUTTER FRAME 40 mm SERIES

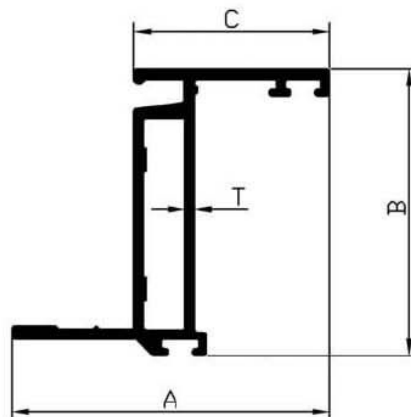

SEC.No.	C/L	A	B	C	T	WT. RANGE
1991	12'	47.00	42.00	29.00	1.40	2.200-2.400

## OUTER FRAME 40 mm SERIES

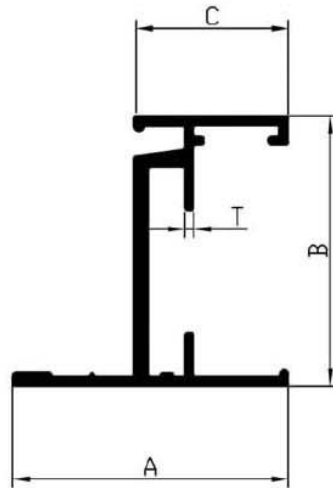

SEC.No.	C/L	A	B	C	T	WT. RANGE
1995	12'	41.00	40.00	22.60	1.20	1.800-2.100
1996	12'	41.00	40.00	22.60	1.40	2.100-2.300

## G - CLIP 40 mm SERIES

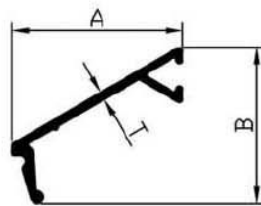

SEC.No.	C/L	A	B	T	WT. RANGE
2001	12'	25.30	23.00	1.20	0.550-0.650



## LOUVER SECTION

SEC.No.-2006

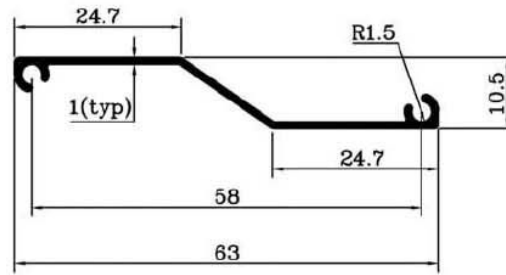

WEIGHT: 0.810 kg/12'

SEC.No.-2007

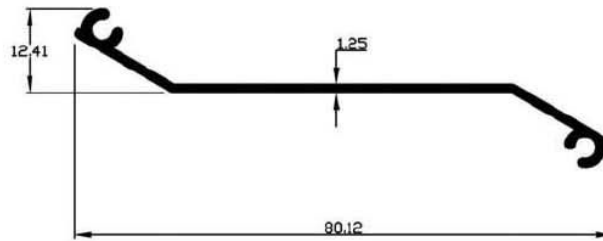

WEIGHT: 1.700 kg/16'

SEC.No.-2011

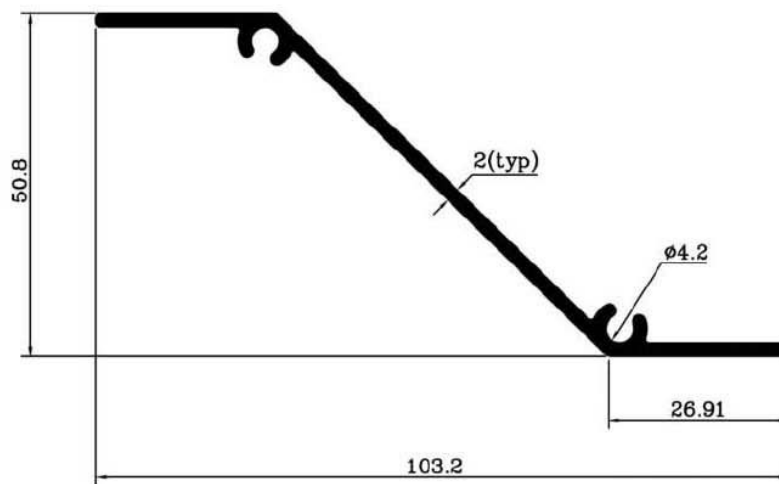

WEIGHT: 2.770 kg/12'

## ROD

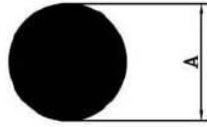

SEC.No.	C/L	A	WT. RANGE
2021	12'	9.000	0.600-0.630
2022	12'	9.100	0.630-0.660
2023	12'	9.400	0.660-0.695
2024	12'	9.700	0.710-0.740
2025	12'	9.800	0.730-0.770
2026	12'	10.00	0.770-0.800
2027	12'	10.70	0.870-0.905
2028	12'	11.40	0.975-1.050
2029	12'	11.60	1.010-1.050
2030	12'	11.90	1.080-1.100
2031	12'	14.40	1.565-1.650
2032	12'	14.80	1.700-1.750
2033	12'	15.50	1.840-1.885
2034	12'	17.30	2.250-2.350

## HEXAGONAL ROD



SEC.No.	C/L	A	WT. RANGE
2051	12'	17.40	2.600-2.650
2052	12'	17.80	2.700-2.760
2053	12'	18.70	3.000-3.100

## FLAT BAR

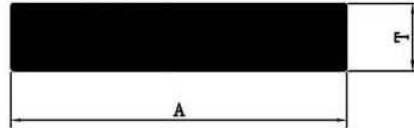

SEC.No.	C/L	A	T	WT. RANGE
2070	12'	25.00	2.000	0.490-0.540
2071	12'	25.00	3.000	0.750-0.850
2072	12'	25.00	5.000	1.200-1.400
2073	12'	25.00	6.000	1.500-1.700
2074	12'	25.00	10.00	2.500-2.700
2075	12'	25.40	5.500	1.250-1.450
2076	12'	25.40	10.00	2.400-2.600
2077	12'	28.00	6.000	1.650-1.850
2088	12'	30.00	6.00	1.750-2.000
2089	12'	30.00	10.00	2.950-3.200
2078	12'	35.00	3.000	1.036-1.136
2092	12'	38.00	6.000	2.200-2.600
2091	12'	38.00	10.00	3.700-4.100
2079	12'	40.00	6.000	2.400-2.600
2080	12'	40.00	10.00	4.000-4.200
2081	12'	50.00	6.000	3.000-3.200
2082	12'	50.00	10.00	4.950-5.150
2083	12'	60.00	10.00	5.800-6.000
2084	12'	75.00	5.000	3.700-3.900
2085	12'	75.00	6.000	4.450-4.650
2086	12'	100.0	6.000	5.900-6.100
2087	12'	100.0	10.00	9.750-9.950
2090	12'	100.0	12.00	11.800-12.200
2091	12'	38.0	10.00	11.800-12.200
2092	12'	38.0	6.00	3.750-4.100
2093	12'	48.0	3.80	1.800-2.000
2094	12'	50.0	4.60	2.300-2.700
2095	12'	19.0	2.50	0.470-0.530

## PLAIN ROUND TUBE

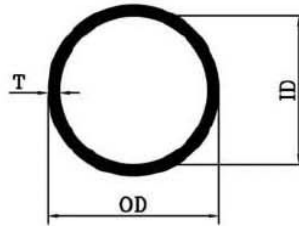

SEC.No.	C/L	OD	ID	T	WT. RANGE
2101	12'	16.00	13.00	1.50	0.600-0.620
2102	12'	16.00	12.80	1.60	0.700-0.720
2100	12'	18.00	16.30	0.85	0.450-0.500
2116	12'	18.00	16.10	0.95	0.500-0.550
2117	12'	18.00	15.80	1.10	0.620-0.720
2118	12'	18.00	15.40	1.30	0.770-0.820
2104	12'	19.10	16.00	1.55	0.700-0.750
2119	12'	19.10	15.80	1.65	0.900-1.000
2103	12'	19.10	12.80	3.15	1.800-1.900
2105	12'	20.00	18.00	1.00	0.550-0.570
2106	12'	25.40	19.10	3.15	2.000-2.100
2107	12'	25.40	22.00	1.70	1.000-1.050
2108	12'	31.50	25.40	3.05	3.300-3.400
2109	12'	31.50	28.00	1.75	1.600-1.700
2110	12'	32.00	19.00	6.50	5.100-5.200
2111	12'	38.00	22.00	8.00	7.350-7.450
2112	12'	38.00	35.00	1.50	1.700-1.800
2113	12'	50.00	40.00	5.00	6.700-6.800
2114	12'	60.00	45.00	5.00	8.400-8.500
2115	12'	63.00	57.00	3.00	6.000-6.200
2120	12'	76.00	70.60	2.70	6.150-6.250

## FLUTED ROUND TUBE

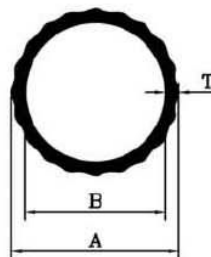

SEC.No.	C/L	A	B	T	WT. RANGE
2131	12'	24.80	20.80	2.00	1.250-1.450
2128	12'	25.40	23.60	0.90	0.450-0.520
2129	12'	25.40	23.40	1.00	0.520-0.600
2130	12'	25.00	22.70	1.35	0.650-0.725

## TOWER BOLT

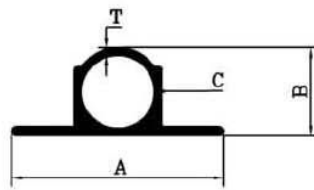

SEC.No.	C/L	A	B	C	T	WT. RANGE
2141	12'	31.50	13.10	10.80	1.10	0.850-0.1050

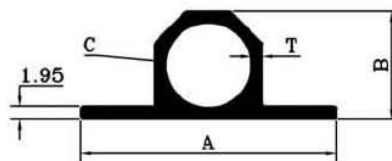

SEC.No.	C/L	A	B	C	T	WT. RANGE
2146	12'	38.00	16.00	12.60	1.70	1.500-1.600

## STEP LADDER

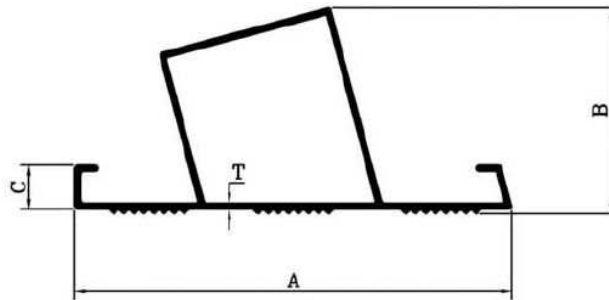

SEC.No.	C/L	A	B	C	T	WT. RANGE
2151	12'	65.00	30.50	6.50	0.90	1.500-1.700
2152	12'	65.00	30.50	6.50	1.10	1.700-2.000

## C LADDER

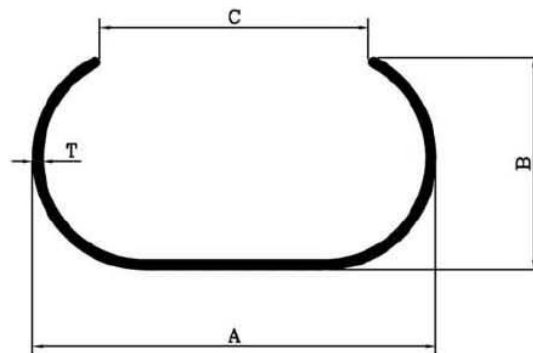

SEC.No.	C/L	A	B	C	T	WT. RANGE
2156	12'	60.00	31.50	40.00	1.50	1.600-1.800
2157	12'	66.00	31.50	40.00	2.40	2.800-3.100
2158	12'	66.00	31.50	40.00	3.00	3.400-3.700

## C HANDLE

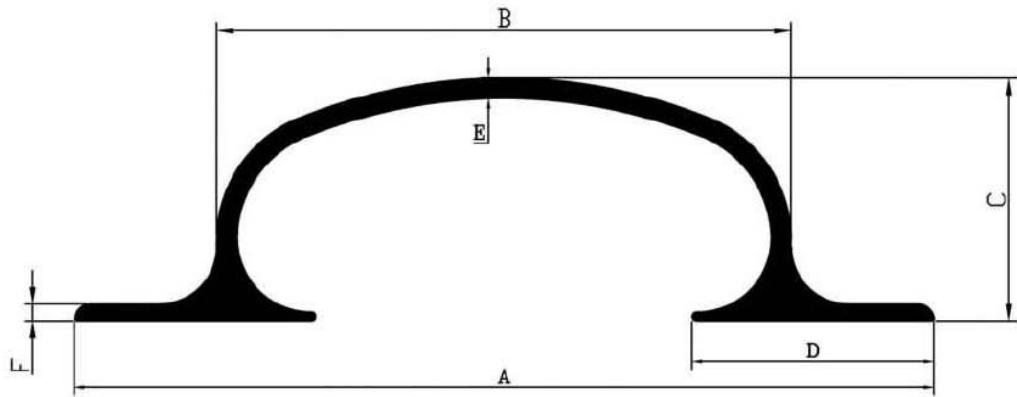

SEC.No.	C/L	A	B	C	D	E	F	WT. RANGE
2166	12'	100.7	64.50	27.80	32.00	2.35	1.80	3.500-3.800
2167	12'	128.0	85.50	36.00	36.00	3.00	2.50	5.900-6.200

## D HANDLE

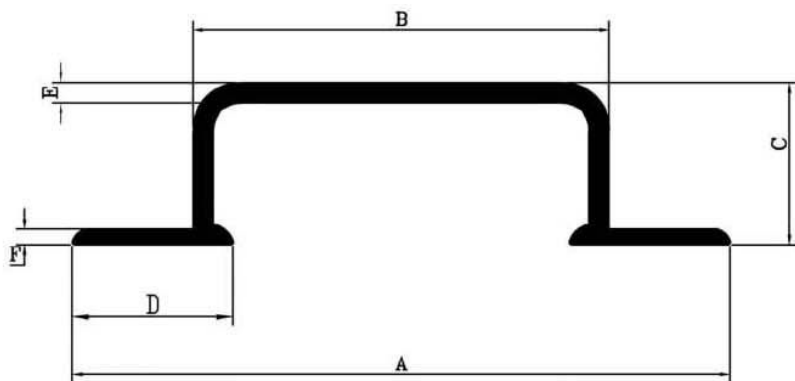

SEC.No.	C/L	A	B	C	D	E	F	WT. RANGE
2176	12'	98.00	62.00	24.00	24.00	3.00	2.30	3.850-4.150
2177	12'	121.0	83.00	30.00	26.50	2.90	3.60	5.500-5.800

## EQUAL ANGLE

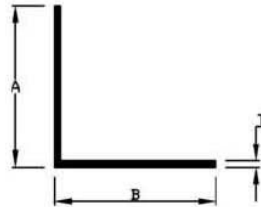

SEC.No.	C/L	A	B	T	WEIGHT
2184	12	19.00	19.00	1.06	0.380-0.420
2185	12	24.00	24.00	0.86	0.350-0.380
2186	12	25.00	25.00	1.00	0.500-0.600
2187	12	25.00	25.00	1.50	0.700-0.800
2191	12	25.00	25.00	1.80	0.850-1.100
2188	12	25.00	25.00	2.35	1.100-1.300
2189	12	25.00	25.00	3.00	1.400-1.600
2190	12	50.00	50.00	3.00	2.900-3.200

## UNEQUAL ANGLE

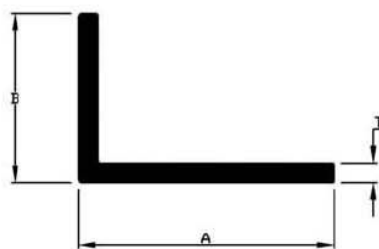

SEC.No.	C/L	A	B	T	WEIGHT
2195	12	38.00	25.00	2.18	1.300-1.600
2196	12	38.00	25.00	2.30	1.600-1.900
2197	12	38.00	25.00	2.90	2.000-2.200
2199	12	50.00	25.00	2.40	1.700-2.000



## BULB TEE

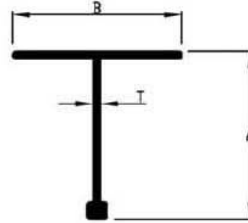

SEC.No.	C/L	A	B	T	WEIGHT
2204	12	24.00	24.00	0.62	0.300-0.500
2206	12	25.00	25.00	1.20	0.600-0.700
2208	12	25.00	25.00	1.45	0.700-0.800
2207	12	38.10	25.40	1.15	0.750-0.850
2209	12	38.10	25.40	1.45	0.950-1.050

## PLAIN TEE

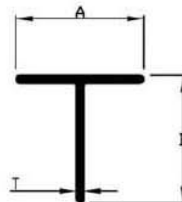

SEC.No.	C/L	A	B	T	WEIGHT
2215	12	19.00	19.00	0.77	0.280-0.350
2216	12	19.00	19.00	1.10	0.400-0.500
2217	12	25.00	25.00	0.90	0.400-0.500

### SEC.No.-2221

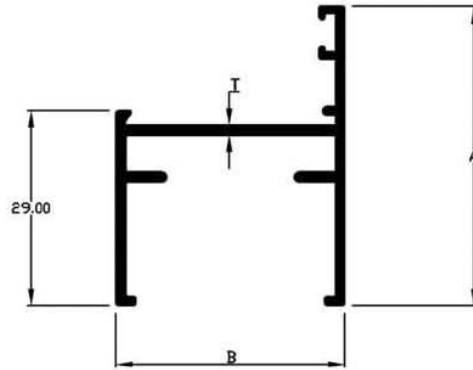

SEC.No.	C/L	A	B	T	WEIGHT
2221	16	44.45	34.0	1.03	1.700-2.000
2222	16	44.45	34.0	1.25	2.000-2.300
2223	16	44.45	34.0	1.45	2.300-2.600
2224	16	44.45	34.0	1.70	2.700-3.000

### G CHANNEL

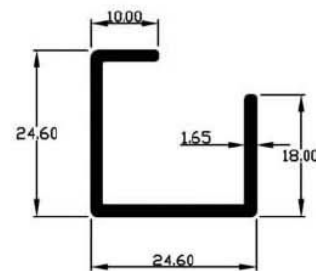
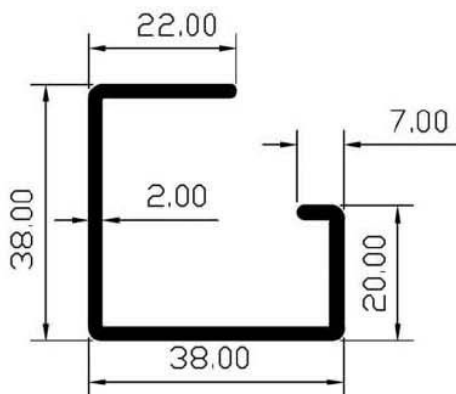

SEC.No.	C/L	A	B	T	WEIGHT
2227	12	24.60	24.60	1.65	1.100-1.500
2226	12	38.00	38.00	2.00	2.200-2.500
2228	12	38.00	38.00	2.35	2.600-2.800
2229	12	38.00	38.00	2.55	2.800-3.100

## DOUBLE GLASS CHANNEL

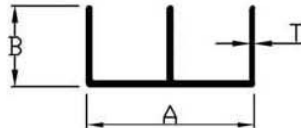

SEC.No.	C/L	A	B	T	WEIGHT
2237	12	16.00	11.00	0.70	0.310-0.360
2238	12	18.00	11.00	0.66	0.310-0.360
2239	12	18.00	11.00	0.80	0.380-0.430
2240	12	18.00	11.00	1.04	0.480-0.530
2244	12	18.50	11.00	0.65	0.310-0.360
2245	12	18.50	11.00	0.80	0.380-0.430
2246	12	18.50	12.00	0.96	0.480-0.530
2243	12	18.50	12.00	1.11	0.550-0.600
2241	12	22.00	11.00	0.63	0.320-0.370
2231	12	22.00	12.00	0.75	0.400-0.450
2232	12	22.00	12.00	1.02	0.550-0.600
2233	12	22.00	12.00	1.20	0.650-0.700
2242	12	25.00	11.00	0.70	0.380-0.430
2234	12	25.00	12.00	0.72	0.400-0.450
2235	12	25.00	12.00	0.93	0.520-0.570
2236	12	25.00	12.00	0.98	0.550-0.600
2247	12	25.00	12.00	1.15	0.650-0.700
2248	12	32.00	12.00	1.02	0.650-0.750
2249	12	35.00	14.00	0.68	0.500-0.550
2250	12	35.00	14.00	0.95	0.690-0.740
2255	12	22.00	11.00		0.240-0.280
2256	12	22.00	11.00		0.280-0.320
2257	12	25.00	12.00		0.280-0.320

## GRILL 'Y' CHANNEL

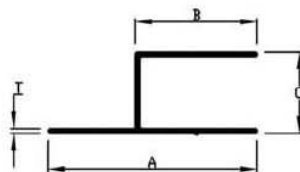

SEC.No.	C/L	A	B	C	T	WEIGHT
2440	12	31.00	18.00	12.00	0.68	0.400-0.500
2441	12	31.00	18.00	12.00	0.87	0.500-0.600

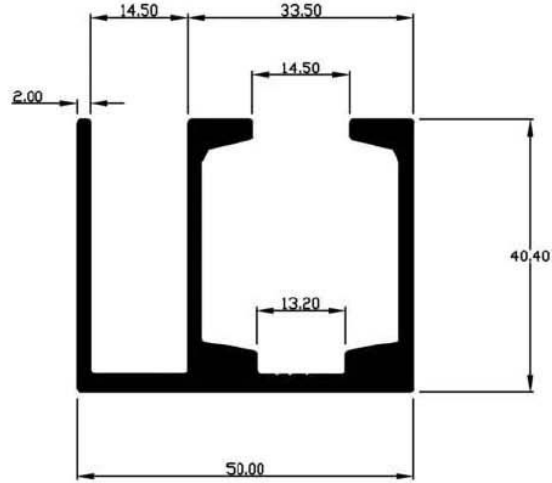
**SEC.No.-2261**

WEIGHT: -4.700-5.000 kg/12'

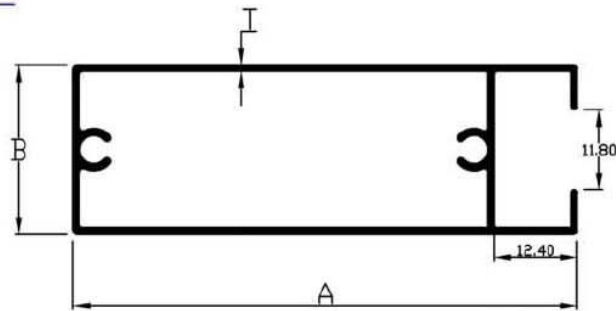
**3 X 1" HANDLE**

SEC.No.	C/L	A	B	T	WEIGHT
2271	16	75.00	25.00	0.90	2.700-3.000

### 3 X 1" TOP BOTTOM

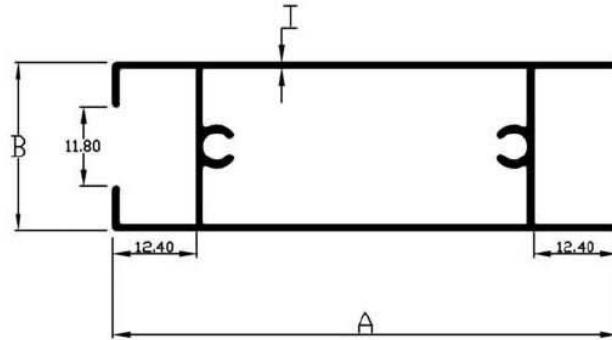

SEC.No.	C/L	A	B	T	WEIGHT
2281	16	75.00	25.00	0.90	2.700-3.000

### 3 X 1" MATTING

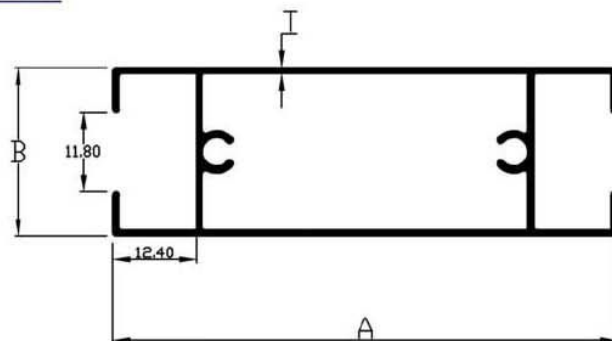

SEC.No.	C/L	A	B	T	WEIGHT
2291	15	75.00	25.00	0.85	2.500-2.800
2290	16	75.00	25.00	0.90	2.800-3.100
2292	16	75.00	25.00	1.00	3.200-3.500

### 3 X 3/4" MATTING

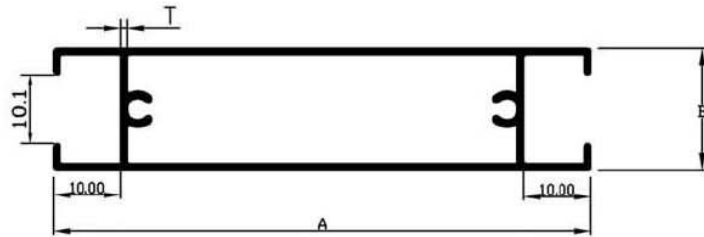

SEC.No.	C/L	A	B	T	WEIGHT
2296	12	80.00	18.00	0.90	2.000-2.300
2297	12	80.00	18.00	1.15	2.400-2.700

### 3 X 3/4" HANDLE

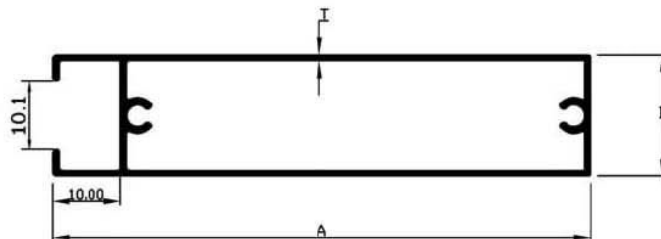

SEC.No.	C/L	A	B	T	WEIGHT
2275	12	80.00	18.00	0.92	2.000-2.200

SEC.No.-2330

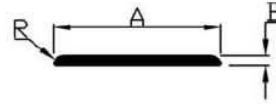
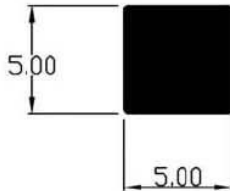

SEC.No.	C/L	A	B	R	WT. RANGE
2354	12'	25.00	1.20	1.60	0.280-0.330
2355	12'	25.00	1.40	1.60	0.350-0.410
2356	12'	25.00	1.60	2.00	0.410-0.460
2357	12'	25.00	1.75	2.00	0.470-0.520

WEIGHT:- 0.245-0.450 kg/12'

SEC.No.-2370

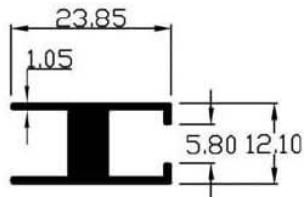

WEIGHT:- 1.134 kg/12'

SEC.No.-2380

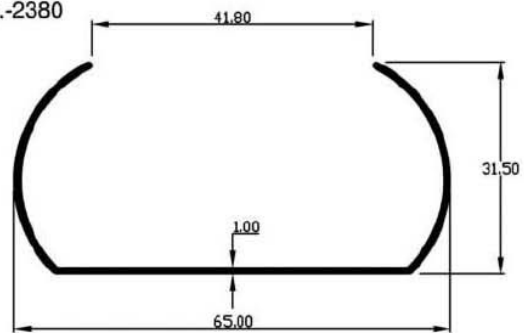

WEIGHT:- 1.200-1.400 kg/12'

SEC.No.-2381

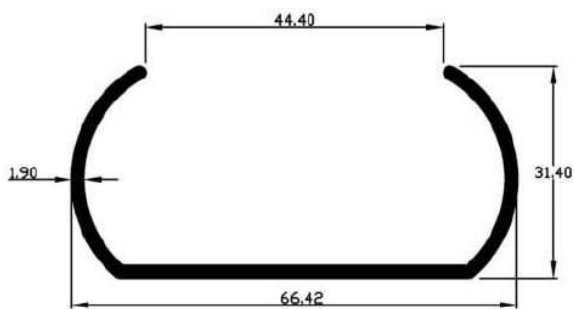

WEIGHT:- 2.300-2.500 kg/12'

SEC.No.-2390

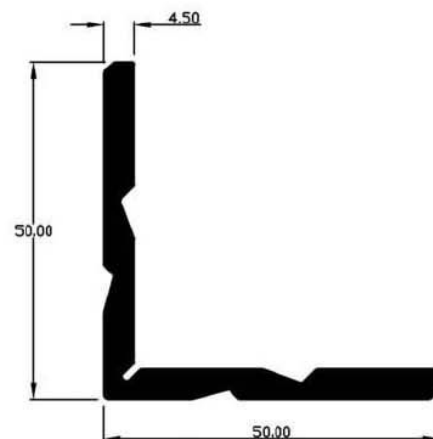

WEIGHT:- 3.900-4.200 kg/12'

SEC.No.-2400

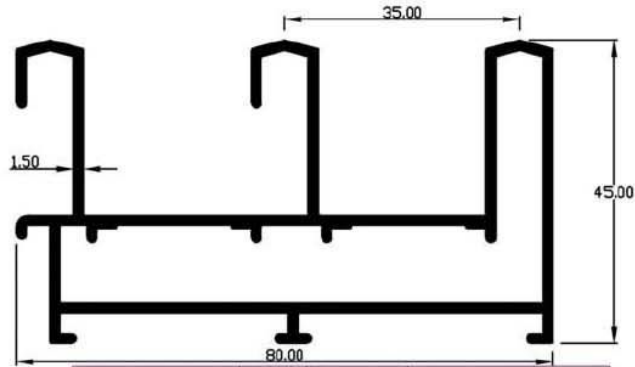

SEC.No.	C/L	T	WEIGHT
2400	12	1.50	5.100-5.400
2401	12	1.20	4.100-4.500

SEC.No.-2405

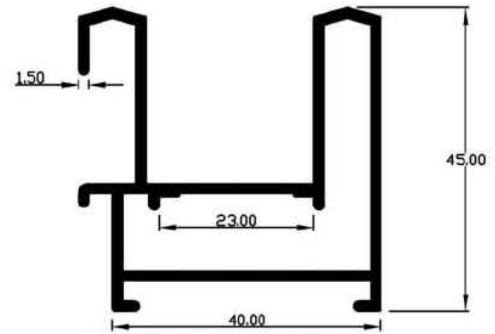

SEC.No.	C/L	T	WEIGHT
2405	12	1.50	3.200-3.500
2406	12	1.20	2.600-2.800

SEC.No.-2411

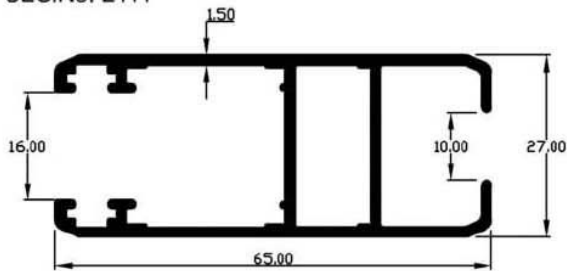

SEC.No.	C/L	T	WEIGHT
2411	12	1.50	3.200-3.500
2412	12	1.20	2.600-2.800

SEC.No.-2416

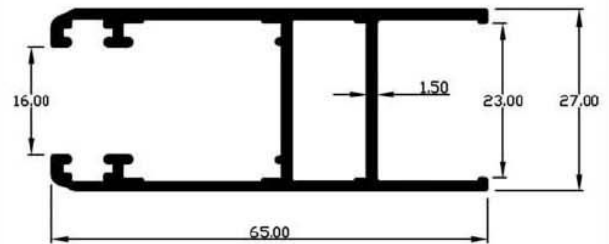

SEC.No.	C/L	T	WEIGHT
2416	12	1.50	3.000-3.200
2417	12	1.20	2.400-2.700

SEC.No.-2421

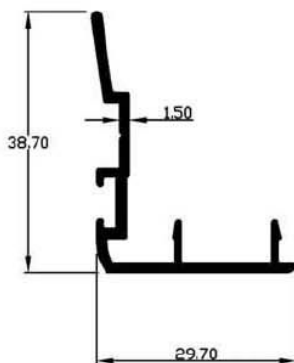

WEIGHT:- 1.200-1.400 kg/12'

SEC.No.-2426

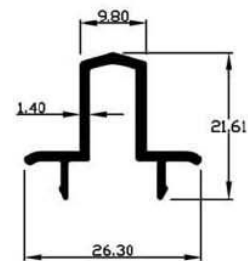

WEIGHT:- 0.850-0.950 kg/12'



SEC.No.-2431

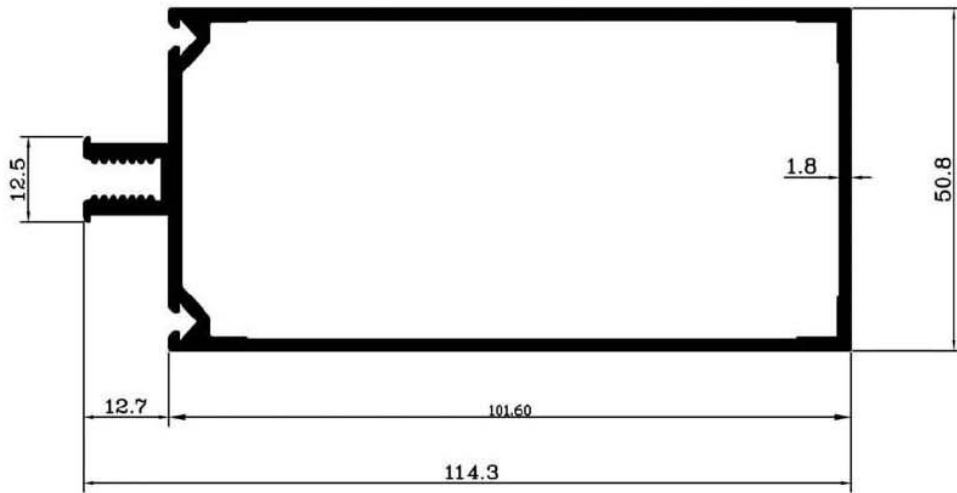

WEIGHT:- 6.350-6.700 kg/12'

SEC.No.-2436

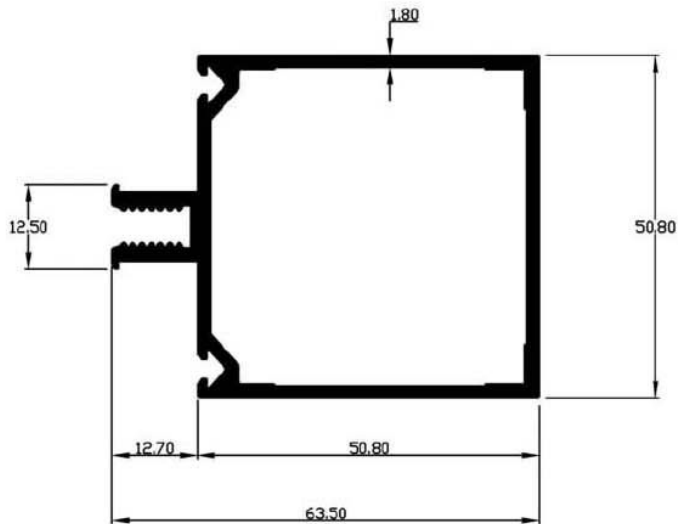

WEIGHT:- 4.500-4.800 kg/12'

SEC. NO:- 2437

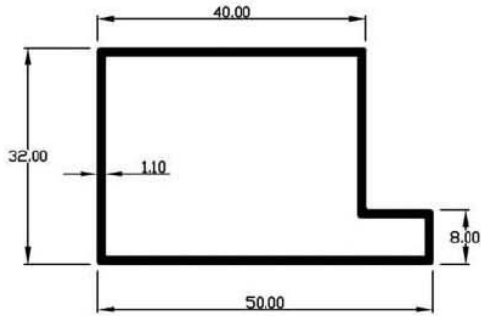

WEIGHT:- 1.700-1.900 kg/12'

SEC. NO:- 2438

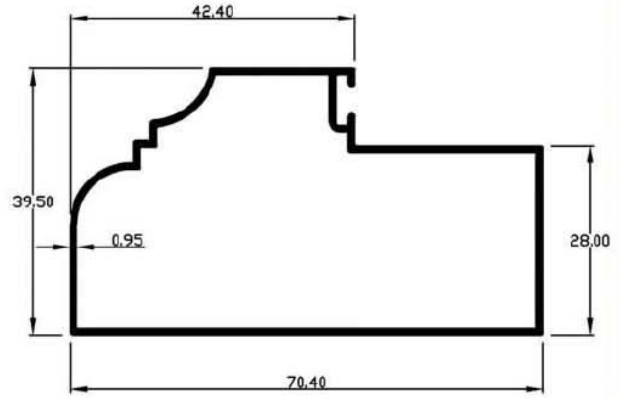

WEIGHT:- 2.000-2.300 kg/12'

SEC. NO:- 2439

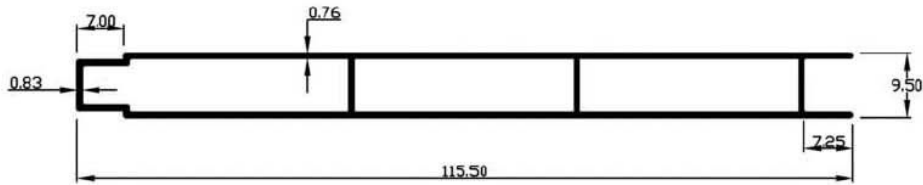
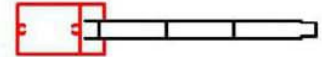

WEIGHT:- 2.000-2.300 kg/12'

SEC. NO:- 2445

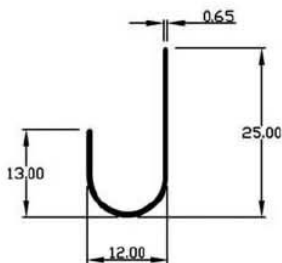

WEIGHT:- 0.280-0.310 kg/12'

SEC. NO:- 2451

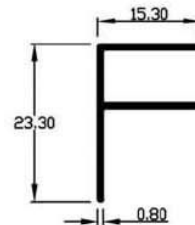

WEIGHT:- 0.400-0.550 kg/12'

SEC. NO:- 2456

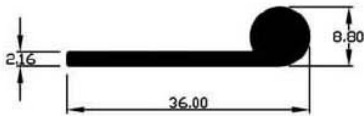

WEIGHT:- 1.200-1.400 kg/12'

SEC. NO:- 2457

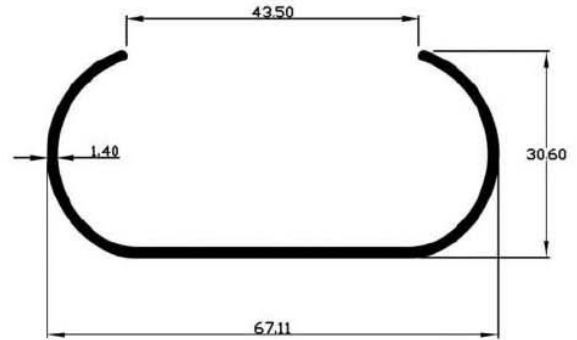

WEIGHT:- 1.700-2.000 kg/12'

SEC. NO:- 2458

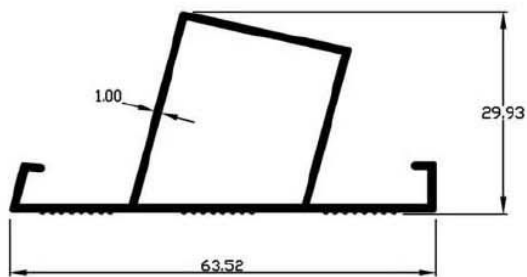

WEIGHT:- 1.600-1.800 kg/12'

SEC. NO:- 2459

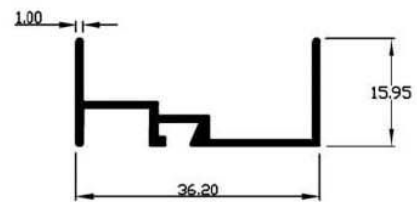

WEIGHT:- 0.800-1.000 kg/12'

SEC. NO:- 2460

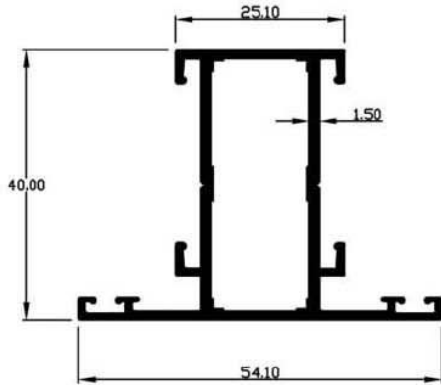

WEIGHT:- 2.500-2.800 kg/12'

SEC. NO:- 2465

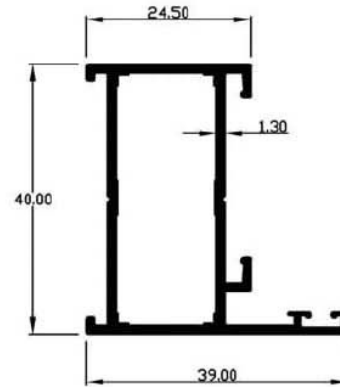

WEIGHT:- 2.000-2.300 kg/12'

SEC. NO:- 2468

VP-125

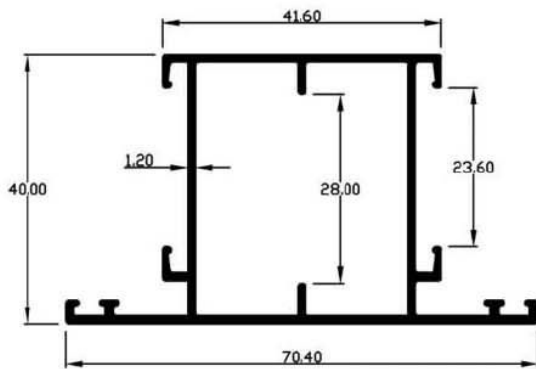

WEIGHT:- 2.700-2.950 kg/12'

SEC. NO:- 2471

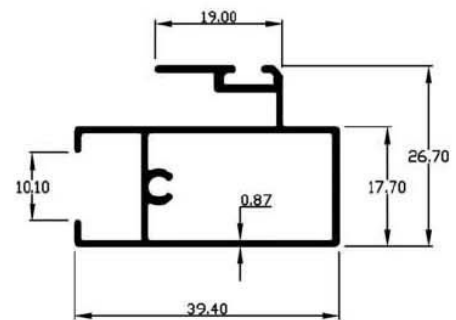

WEIGHT:- 1.390-1.540 kg/12'

SEC. NO:- 2470

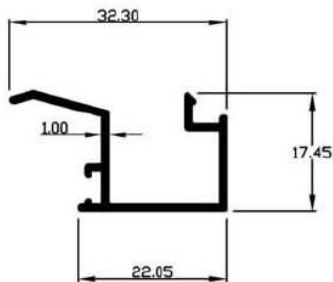

WEIGHT:- 0.750-0.950 kg/12'

SEC. NO:- 2476

VP-121

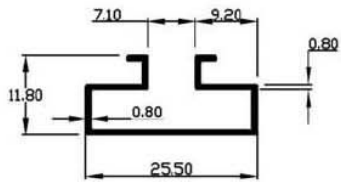

WEIGHT:- 0.550-0.750 kg/12'

SEC. NO:- 2481

VP-153(M)

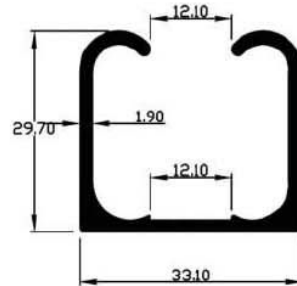

WEIGHT:- 2.000-2.200 kg/12'

SEC. NO:- 2486

VP-173

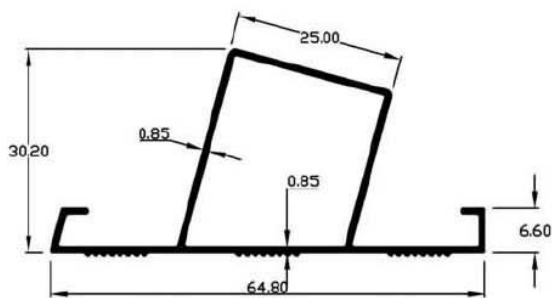

WEIGHT:- 1.400-1.700 kg/12'

SEC. NO:- 2491

VP-174

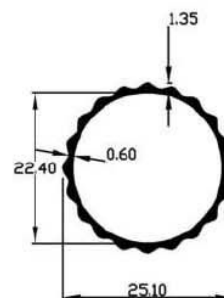

WEIGHT:- 0.700-0.900 kg/12'

SEC. NO:- 2496

VP-123

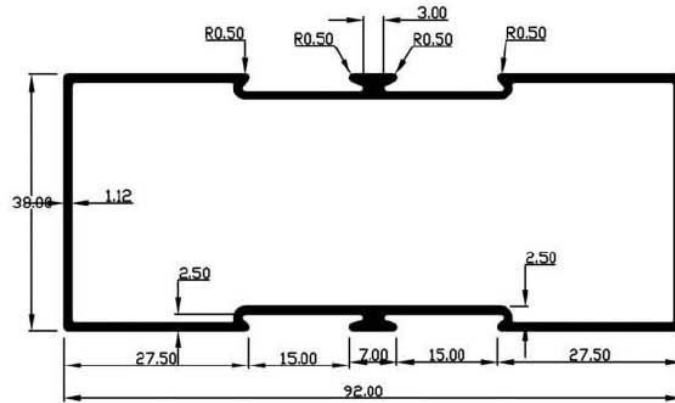

WEIGHT:- 3.200-3.500 kg/12'

SEC. NO:- 2501

VP-124

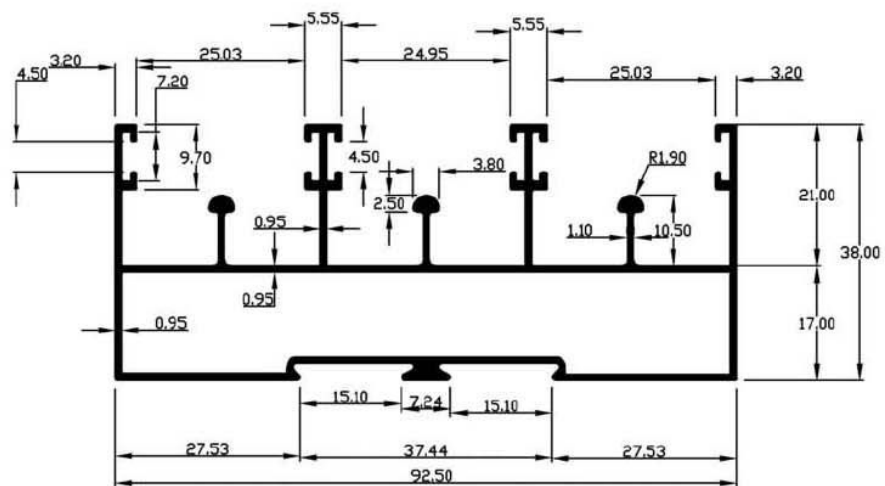

WEIGHT:- 4.000-4.300 kg/12'

SEC. NO:- 2506

VP-126

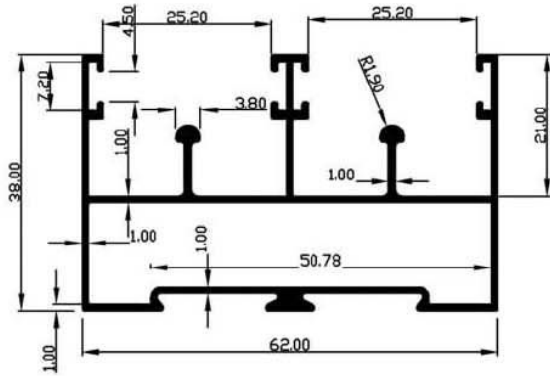

WEIGHT:- 3.000-3.300 kg/12'

SEC. NO:- 2511

VP-136

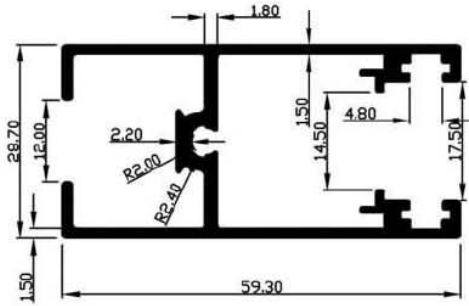

WEIGHT:- 3.200-3.500 kg/12'

SEC. NO:- 2516

VP-137

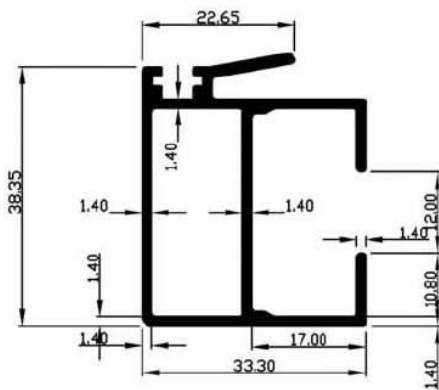

WEIGHT:- 2.400-2.700 kg/12'

SEC. NO:- 2521

VP-138

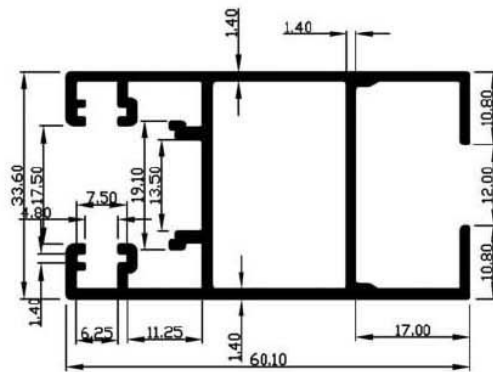

WEIGHT:- 3.500-3.800 kg/12'

SEC. NO:- 2526

VP-184

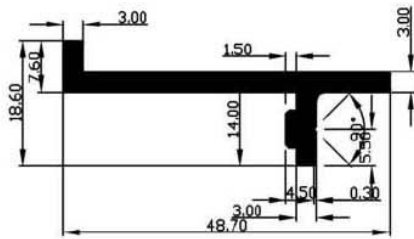

WEIGHT:- 1.950-2.250 kg/12'